

DC-DC Converter AVP/KEP

Output power up to 200 Watts

Isolated – Single Output
Standard euro-rack size 19"



Special Features

- Electrostatic discharge: 8kV contact (chassis), 15 kV air, (level 4) according to EN 61000-4-2:2009
- Fast transients (Burst): 2 kV (level 3) / (criterion A) / according to EN 61000-4-4:2004
- Surge: Input immunity 2 kV sym./asym. criterion A according to EN 61000-4-5:2006
- Conducted immunity 10V/m according to EN 61000-4-6:2007
- Conducted emission:
Input filtering according to EN 55022:2006 class B***
- Zero load operation and short circuit protection
- Overtemperature shutdown
- Remote off (EN) with TTL – L-signal
- Overvoltage protection in the output, even in case of external supply (OVP)
- Reverse polarity protection by internal diode
- Extremely low thermal stress of sensitive components due to dissipated power loss over lateral heatsink
- Yellow LED indicate operating mode
- Hold up time S2 according to EN 50155 (> 10 ms at $V_{in\ nom}$, $I_{out\ nom}$) only for 09 50 74 0103 7 Converter

Technology

- Power section in 100kHz-MOS-FET-technology
- Regulator section in SMT
- Coated assembly
- Coated and glued parts for better vibration resistance

Specifications

at $v_{amb}=25^{\circ}\text{C}$, $V_{in\ nom}$, $I_{out\ nom}$

Temperature	
Ambient air	$v_{amb} = -40^{\circ}\text{C}...+85^{\circ}\text{C}$
Storage	$v_S = -40^{\circ}\text{C}...+100^{\circ}\text{C}$
Rise inside chassis	$\Delta v_{Ci} \leq 20\text{K}$
Rise on heat sink	$\Delta v_K \leq 35\text{K}$
Output voltages (output 1)	
Tolerance	$\Delta V_{out} \leq \pm 0,5\%^*$
Ripple at $v_{amb} = -40^{\circ}\text{C}...+85^{\circ}\text{C}$	$V_{out\ ripple} \leq 3,5\%$
Temperature coefficient	$TC \leq 0,016\%/K$
Regulation at $v_{amb} = -40^{\circ}\text{C}...+85^{\circ}\text{C}$	
Line reg. for $V_{in\ range}$	$\Delta V_{out} \leq 2\text{mV}$
Load reg. static	$\Delta V_{out} \leq 10\text{mV/A}$
Load change (25°C)**	$\Delta V_{out} \leq 38\ (23)\text{mV/A}$
Output "Power Good"	
Admissible voltage	$V_{CEO} \leq 24\ \text{V}$
Admissible current	$I_C \leq 20\ \text{mA}$
Saturation voltage	$V_{CE(sat)} \leq 1,2\ \text{V}$
OVP	
Starting point /%	$V_{out\ off} \leq 130\% V_{out\ nom}$
Admissible continuous external current	$I_{ext} \leq 6\ \text{A}$
Isolation – voltage strength	
In-/Output	$V_{iso\ i/o} \geq 1,5\ \text{kVrms}$
Input to case	$V_{iso\ i/c} \geq 1,5\ \text{kVrms}$
Output to case	$V_{iso\ o/c} \geq 0,5\ \text{kVrms}$
Resistance In-/Output	$R_{iso} \geq 1,5\ \text{GOhm}$
Capacitance In-/Output	$C_{iso} \leq 4700\ \text{pF}$
Degrees of protection (inserted in rack)	= IP20***
Weight AVP/KEP	M ca. 1070g

Block Diagram

- 4 = $-V_{out1}$
- 6 = $+V_{out1}$
- 8 = +S (Sense)
- 10 = -S (Sense)
- 12 = n.c.
- 14 = n.c.
- 16 = n.c.
- 18 = -PG (-Power Good)
- 20 = +PG (+Power Good)
- 22 = TR (Tracking)
- 24 = EN (ON/OFF)
- 26 = GND (TR and EN)
- 28 = $+V_{in}$
- 30 = $-V_{in}$
- 32 = ∇ / \oplus

Sense connection is not required.

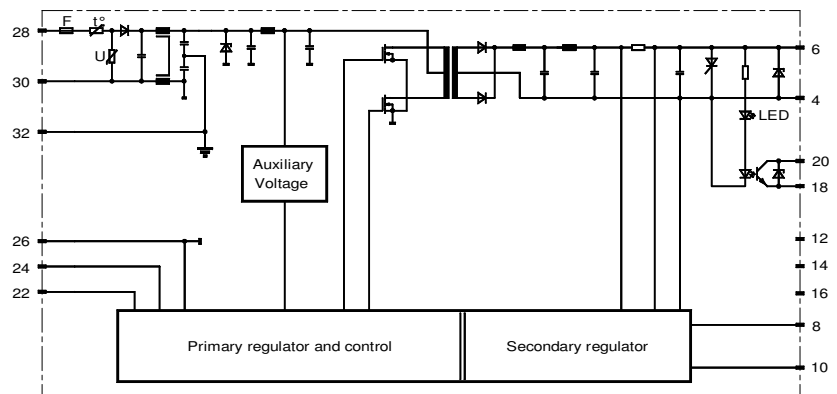

* $I_{out\ min} = 0,1 I_{out\ nom}$

** Higher degrees of protection by properly mounting

*** In built-in condition our devices may show different EMC properties

Drawing

Dimensions in mm
Tolerance: general $\pm 1\text{mm}$

Front panel DIN ISO 2768-1m

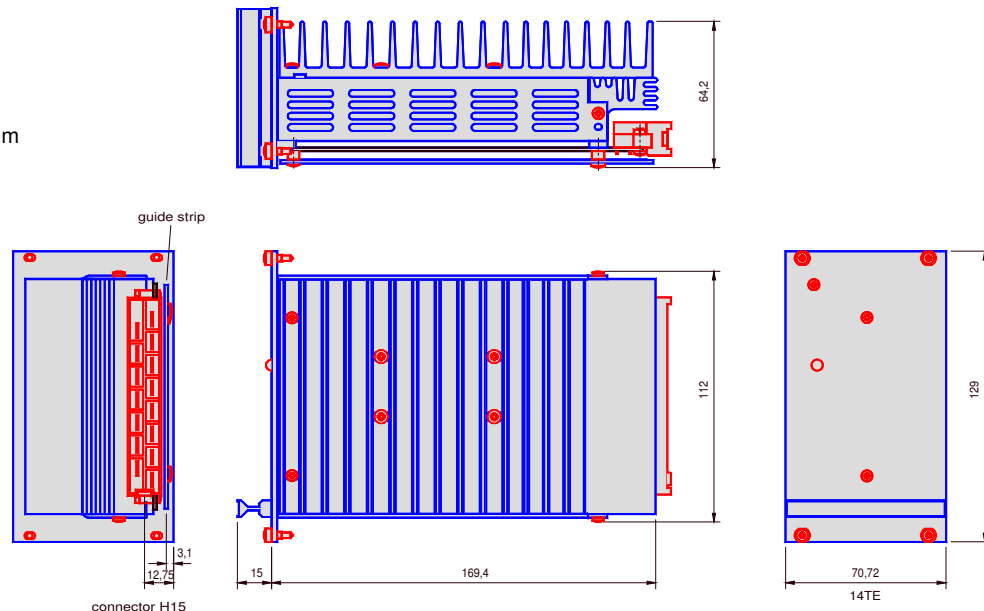

Operating Instructions

Installation: The converters have to be installed according to the guidelines currently in force, like other open electronic component assemblies. Attention must be paid to sufficient ventilation, fastening and protection against accidental contact! Plug in not under voltage if converter connected parallel or in series.

Protection: The converters are equipped with a soldered-in time-lag fuse corresponding to IEC 127-2 for input protection. For rating of fuse refer to listing below. Pay attention on sufficient current of current source in case of short-circuit.

Connector pin 32 (V/⊕) - Equipotentiality/PE: This pin has to be properly connected in order to assure operation.

Excess temperature protection: In case of inside temperatures exceeding $>101^\circ\text{C}$, typ. 105°C , (due to inadmissible operation conditions) the output voltages are automatically switched off and restarted after cooling down about 10 K.

External shutdown (EN): $V < 0,8\text{ V}$ at pin 24 (EN) to pin 26 or connecting an active transistor with open collector to this pins switches off the output. $I_{\text{source}} 500\ \mu\text{A}$

Overvoltage protection: Externally or internally caused overvoltage at the output leads to a thyristor controlled short-circuit and shut-down of the output. After elimination of the overvoltage the output voltage restarts automatically latest after 1s.

Output voltage monitoring (Power Good): Simultan to the lighting of a LED a transistor with open-collector switches on. Level V_{PG} see table below.

Current limiting: $I_{\text{out lim}} = 1,1 \dots 1,2 I_{\text{out nom}}$. At more than $1,5 I_{\text{out nom}}$, the output switches off and restarts automatically latest after 5s of elimination of the overload.

Capacitive load: When switching on (by connecting to the input voltage or by means of a control signal at the input "EN") the DC-DC converters can drive capacitive loads up to 100 mF parallel to the nominal load. At overload conditions the switching on period takes approx. 375 ms. After elimination of the overload the output voltage restarts automatically latest after 5 s.

Tracking operation: If the pins 22 as well as 26 of two or more converters are connected, the output voltages in case of short-circuit or overload go synchronously down and restart at the same moment.

Sense operation: Sense connection is not required. If it is accomplished, the voltage at the load is reduced by approx. 100 mV. The voltage drop on the interconnection leads between the converter and the load should not exceed 0,5 V.

Standard converters AVP/KEP

V_{out} V	I_{out} A	η ²⁾ %	Type	V_{PG} ³⁾ VDC	$V_{in,nom}$ VDC	$V_{in,operating}$ VDC	$V_{in,range}$ VDC	$I_{in,max}$ A	Internal Fuse A	Order Number
12	12 ¹⁾	85	AVP/KEP	>10	72	50...90	43...101	4	6,3	09 50 22 0102 6
15	10 ¹⁾	85		>13	72	50...90	43...101	4,3	6,3	09 50 23 0102 5
15	10 ¹⁾	87		>13	110	77...138	66...154 ⁴⁾	2,6	5	09 50 73 0102 4
24	6 ¹⁾	84		>21	24	16...30	15...36	11,5	16	09 50 94 0102 8
24	6 ¹⁾	83		>21	36	25...45	19...51	9,5	16	09 50 34 0102 2
24	7 ⁷⁾	87		>21	72	50...90	43...101	4,7	6,3	09 50 24 0102 4
24	9 ⁵⁾⁶⁾	87		>21	110	77...138	66...154 ⁴⁾	3,5	5	09 50 74 0102 3
24	9 ⁵⁾⁶⁾	87		>21	110	77...138	66...154 ⁴⁾	3,9	5	09 50 74 0103 7 ⁸⁾

Order numbers for option "EMC fingerstrips" and other options on request

- 1) Derating between 70 °C and 85 °C: 4%/°C
- 2) At $V_{in,nom}$; typical
- 3) V_{PG} = Switching point for the output level for "Power Good"
- 4) 176 V for 100 ms permissible
- 5) $I_{out,lim} = 1,05...1,15 I_{out,nom}$
- 6) Derating between 60 °C and 70 °C: 0,1 A /°C; 70 °C and 85 °C: 0,32 A/°C
- 7) Derating between 60 °C and 70 °C: 0,1 A /°C; 70 °C and 85 °C: 0,25 A/°C
- 8) With hold up time S2 according to EN 50155 (> 10 ms at $V_{in,nom}$, $I_{out,nom}$)

Innovative Energies Ltd
1 Heremai Street, Henderson 0610
Auckland, New Zealand
Tel. (09) 835 0700 Fax (09) 837 3446
<http://www.innovative.need.co.nz>
E-Mail: info@innovative.co.nz
DIN EN ISO 9001 certified