

## DC-DC Converter AVP/Ks, .../Ksl, .../Ksp

### Output power up to 78 Watts

Isolated – Single Output  
PCB (AVP/Ksp) and Chassis Mounting (AVP/Ks, .../Ksl)



AVP/Ks



AVP/Ksp

### Block Diagram

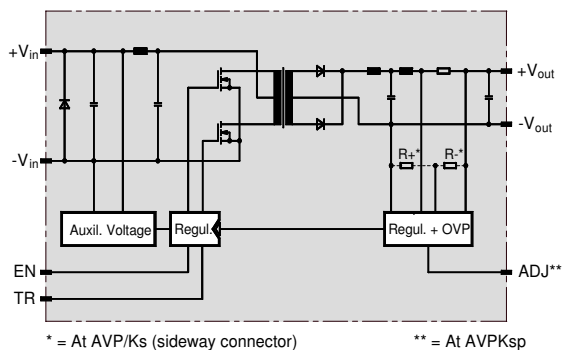

### Technology

- MOSFET design
- Regulators in surface mount technology

### Special Features

- Electrostatic discharge according to EN 61000-4-2:2009 (testing level 4): 8 kV contact (base plate)/ 15 kV air
- Burst transients according to EN 61000-4-4:2004 (class 3): 2 kV
- Surge according to EN 61000-4-5:2006 (class 2): 0,5 kV symmetric
- Conducted immunity according to EN 61000-4-6:2007
- Conducted emission:
  - Input filtering according to EN 55022:2006, class B (QP)\*
- Reverse polarity protection (by external fuse)
- Zero load operation and short circuit protected
- Parallel and series connection
- Overtemperature shutdown
- No overshoot of output voltage at switching on
- Remote off (EN) with TTL – L-signal
- Overvoltage protection in the output circuit, even in case of external supply (OVP)
- Extremely low thermal stress of sensitive components due to dissipated power loss over mounting surface
- Vibration resistant and indifferent to humidity due to encapsulated case

### Specifications

at  $\vartheta_{amb}=25^{\circ}\text{C}$ ,  $V_{in\ nom}$ ,  $0,62 I_{out\ nom}$

|  |                              |  |
|--|------------------------------|--|
| Temperature  |                              |  |
| Ambient air  | $\vartheta_{amb}$            | = $-40^{\circ}\text{C}...+85^{\circ}\text{C}$  |
| Storage  | $\vartheta_S$                | = $-40^{\circ}\text{C}...+100^{\circ}\text{C}$ |
| Rise in case   | $\Delta \vartheta_{C\ perm}$ | $\leq 20\ \text{K}$                            |
| Permissible rise on base plate   | $\Delta \vartheta_{B\ perm}$ | $\leq 25\ \text{K}$                            |
| Necessary thermal resistance of mounting surface (chassis) to ambient          | $R_{thBA}$                   | $\leq 3\ \text{K/W}$                           |
| Output voltages  |                              |  |
| Tolerance (AVP/Ks)   | $\Delta V_{out}$             | $\leq \pm 0,25\ (0,5)\%$ **                    |
| Output ripple at $\vartheta_{amb} = -40^{\circ}\text{C}...+85^{\circ}\text{C}$ | $V_{out\ ripple}$            | $\leq 3,5\%$                                   |
| Temperature coefficient  | $TC$                         | $\leq 0,016\%/K$                               |
| Regulation at $\vartheta_{amb} = -40^{\circ}\text{C}...+85^{\circ}\text{C}$    |                              |  |
| Line reg. for $V_{in\ range}$  | $\Delta V_{out}$             | $\leq 2\text{mV}$                              |
| Load reg. static   | $\Delta V_{out}$             | $\leq 10\text{mV/A}^{***}$                     |
| Load change ( $25^{\circ}\text{C}$ )   | $\Delta V_{out}$             | $\leq 38\ (23)\text{mV/A}^{****}$              |
| OVP  |                              |  |
| Starting point /%  | $V_{out\ off}$               | $\leq 130\% V_{out\ nom}$                      |
| Admissible continuous external current   | $I_{ext}$                    | $\leq 4,5\ \text{A}$                           |
| Isolation voltage-strength   |                              |  |
| In-/Output   |                              | $\geq 1,5\ \text{kVrms}$                       |
| Input to base plate  |                              | $\geq 1,5\ \text{kVrms}$                       |
| Output to base plate   |                              | $\geq 0,5\ \text{kVrms}$                       |
| Resistance In-/Output  | $R_{iso}$                    | $\geq 1,5\ \text{GOhm}$                        |
| Capacitance In-/Output   | $C_{iso}$                    | $= 2200\ \text{pF}$                            |
| Weight AVP/Ks, .../Ksl / AVP/Ksp   | $M$                          | ca. 315/295g                                   |

\* In built-in condition our devices may show different EMC properties

\*\* At 3,3 V and 5 V double values

\*\*\* At AVP/Ksp 9 mV smaller values

\*\*\*\*  $I_{out\ nom} = 0,1 I_{out\ nom}$ , At the AVP/Ksp 5 mV smaller values

# Drawings

Dimensions in mm  
Tolerance: general  $\pm 1$ mm

Hole  $\varnothing 3.5$ mm, area  $\varnothing 6$ mm blank  
For alternative ground connection  
(see notes "Installation")

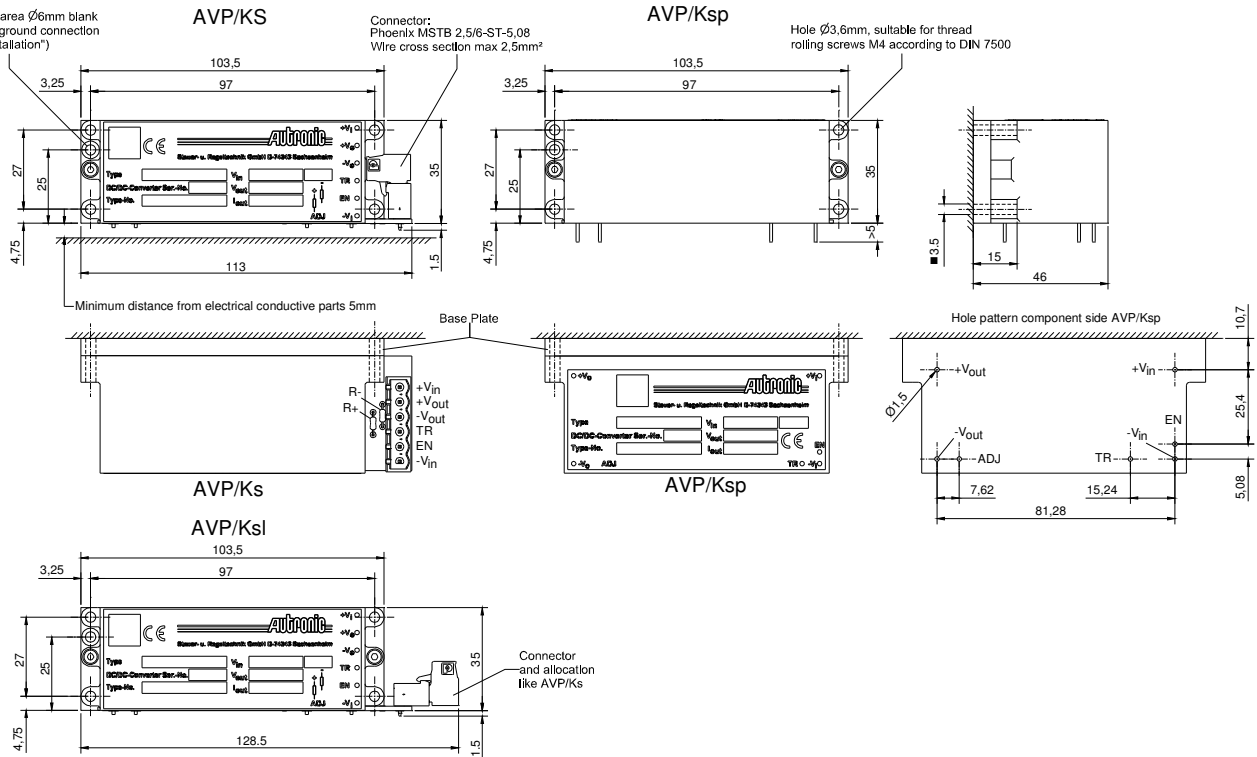

## Operating Instructions

**Installation:** The converters have to be installed according to the guidelines currently in force, like other open electronic component assemblies. Attention must be paid to sufficient ventilation, fastening and protection against accidental contact! The mounting surface has to be even with a thermal resistance as described under "Specifications". If more than one converter is mounted on the same mounting surface the thermal resistance has to be divided by the quantity of converters used. The base plate has to be grounded by using thread rolling screws M 4 according to DIN 7500. An alternative connection to ground can be realized by a special mounting hole, which is free of anodizing surface. Pay attention to ESD handling procedures.

**Caution:** The Pins on the PCB can carry dangerous voltages!

**Reverse polarity protection:** If reverse polarity connection of the input voltage can not be excluded, an external time-lag fuse must be installed. Size:  $I_{rat} = 1,5 \times I_{in,max}$  (max. 16 A). Pay attention on sufficient current of current source in case of short-circuit.

**Excess temperature protection:** In case temperature exceeds 101 °C, typ. 105 °C, (due to inadmissible operation conditions) the output voltage is automatically switched off and restarted after cooling down about 10 K.

**Overvoltage protection:** Externally or internally caused overvoltage at the output leads to a thyristor-controlled short-circuit and shutdown of the output. After elimination of the overvoltage the output voltage restarts automatically.

**External shut down (EN):** The pin "EN" is connected internal to 5 V through a pull up resistor 10 kOhm. The voltage at open pin "EN" is  $V_{EN} = 3,1$  V. Pulling down  $V_{EN} < 0,6$  V (e.g. with a transistor) disables the converter.

**Current limiting:**  $I_{out,lim} = 1,1 \dots 1,2 I_{out,nom}$ . At more than  $1,5 I_{out,nom}$ , the output switches off and restarts automatically latest after 1 s of elimination of the overload.

**Tracking operation:** If the TR pins of two or more converters are connected, the output voltages in case of short-circuit or overload go synchronously down.

**Adjustment:** Connection of the pins "ADJ" and "-V<sub>out</sub>" for the AVP/Ksp modules or inserting a wire to "R+" for the AVP/Ks, .../Ksl modules increases the output voltage of about 8%. Intermediate values are obtained by means of a resistor. By connecting "ADJ" and "+U<sub>out</sub>" pins for the AVP/Ksp by means of a resistor i.e. adding a resistor for "R-" for the AVP/Ks, .../Ksl ensure that the output may be lowered by max. 8%.

# Standard converters AVP/Ks, AVP/Ksl and AVP/Ksp

The order numbers consist of eleven digits (eight for the basis number and three for the version number for the connector options).

| V <sub>out</sub><br>V | I <sub>out nom</sub> <sup>2)</sup><br>A | V <sub>in nom</sub><br>V | V <sub>in range</sub><br>V | I <sub>in max</sub><br>A | η <sup>3)</sup><br>% | f<br>kHz | Order Number |      |      |      |
|-----------------------|---|--------------------------|----------------------------|--------------------------|----------------------|----------|--------------|------|------|------|
|                       |   |                          |                            |                          |                      |          | AVP          | Ks   | Ksl  | Ksp  |
| 3,3 <sup>1)</sup>     | 10,0                                    | 12/24                    | 5...36 <sup>4)</sup>       | 10,0                     | 72                   | 67       | 09 39 80 01  | 12 9 | 13 4 | 72 9 |
| 5 <sup>1)</sup>       | 7,2                                     | 12/24                    | 5...36 <sup>4)</sup>       | 10,0                     | 78                   | 67       | 09 39 81 01  | 12 8 | 13 3 | 72 8 |
|                       | 8,8                                     | 12/24                    | 9...40                     | 6,4                      | 81                   |          | 09 36 61 01  | 12 3 | 13 7 | 72 3 |
|                       | 10,4                                    | 24                       | 5...36                     | 4,5                      | 84                   |          | 09 39 91 01  | 12 6 | 13 1 | 72 6 |
|                       | 11,2                                    | 48                       | 32...74                    | 2,3                      | 84                   |          | 09 39 51 01  | 12 5 | 13 9 | 72 5 |
|                       | 11,2                                    | 110                      | 66...154                   | 1,1                      | 85                   |          | 09 39 71 01  | 12 1 | 13 5 | 72 1 |
| 12                    | 3,2                                     | 12/24                    | 5...36 <sup>4)</sup>       | 10,4                     | 79                   | 67       | 09 39 82 01  | 12 7 | 13 7 | 72 7 |
|                       | 4,3                                     | 12/24                    | 9...40                     | 7,2                      | 84                   |          | 09 39 62 01  | 12 2 | 13 6 | 72 2 |
|                       | 5,3                                     | 24                       | 15...36                    | 5,0                      | 86                   |          | 09 39 92 01  | 12 5 | 13 9 | 72 5 |
|                       | 4,3                                     | 36                       | 19...51                    | 3,1                      | 82                   |          | 09 39 32 01  | 12 8 | 13 6 | 72 8 |
|                       | 5,8                                     | 48                       | 32...74                    | 2,4                      | 89                   |          | 09 39 52 01  | 12 4 | 13 8 | 72 4 |
|                       | 5,8                                     | 110                      | 66...154                   | 1,1                      | 90                   |          | 09 39 72 01  | 12 9 | 13 4 | 72 9 |
| 15                    | 2,7                                     | 12/24                    | 5...36 <sup>4)</sup>       | 10,7                     | 80                   | 67       | 09 39 83 01  | 12 6 | 13 1 | 72 6 |
|                       | 3,7                                     | 12/24                    | 9...40                     | 7,5                      | 85                   |          | 09 39 63 01  | 12 1 | 13 5 | 72 1 |
|                       | 4,8                                     | 24                       | 15...36                    | 5,5                      | 89                   |          | 09 39 93 01  | 12 4 | 13 8 | 72 4 |
|                       | 4,8                                     | 48                       | 32...73                    | 2,6                      | 88                   |          | 09 39 53 01  | 12 3 | 13 7 | 72 3 |
|                       | 4,8                                     | 110                      | 66...154                   | 1,3                      | 90                   |          | 09 39 73 01  | 12 8 | 13 3 | 72 8 |
| 24                    | 1,8                                     | 12/24                    | 5...36 <sup>4)</sup>       | 11,0                     | 80                   | 67       | 09 39 84 01  | 12 5 | 13 9 | 72 5 |
|                       | 2,4                                     | 12/24                    | 9...40                     | 7,9                      | 85                   |          | 09 39 64 01  | 12 9 | 13 4 | 72 9 |
|                       | 3,2                                     | 24                       | 15...36                    | 5,9                      | 89                   |          | 09 39 94 01  | 12 3 | 13 7 | 72 3 |
|                       | 2,9                                     | 36                       | 19...51                    | 4,1                      | 90                   |          | 09 39 34 01  | 12 6 | 13 1 | 72 6 |
|                       | 3,2                                     | 48                       | 32...74                    | 2,7                      | 88                   |          | 09 39 54 01  | 12 2 | 13 6 | 72 2 |
|                       | 3,2                                     | 72                       | 43...101                   | 2                        | 88                   |          | 09 39 24 01  | 12 8 | 13 3 | 72 8 |
|                       | 3,2                                     | 110                      | 66...154                   | 1,3                      | 90                   |          | 09 39 74 01  | 12 7 | 13 2 | 72 7 |
| 30                    | 1,6                                     | 12/24                    | 5...36 <sup>4)</sup>       | 12,8                     | 80                   | 67       | 09 39 85 01  | 12 4 | 13 8 | 72 4 |
|                       | 2,2                                     | 12/24                    | 9...40                     | 9,1                      | 85                   |          | 09 39 65 01  | 12 8 | 13 3 | 72 8 |
|                       | 2,6                                     | 24                       | 15...36                    | 5,8                      | 90                   |          | 09 39 95 01  | 12 2 | 13 6 | 72 2 |
|                       | 2,6                                     | 48                       | 32...74                    | 2,7                      | 90                   |          | 09 39 55 01  | 12 1 | 13 5 | 72 1 |
|                       | 2,6                                     | 110                      | 66...154                   | 1,3                      | 91                   |          | 09 39 75 01  | 12 6 | 13 1 | 72 6 |

1) Adjusted to 3,4 resp. 5,1 V. Admissible avg. current I<sub>avg</sub> = 0,8 I<sub>out nom</sub> + derating

2) For  $\vartheta_{amb} = -40^{\circ}\text{C} \dots 55^{\circ}\text{C}$ . Derating from 55°C to 85°C: 1,25%/°C, I<sub>out</sub> between 85°C and 95°C linear decreasing to 0 A

3) At V<sub>in nom</sub> and 0,6 I<sub>out nom</sub>

4) Converter switches on at V<sub>in</sub> > 8 V  
In case of operation at V<sub>in</sub> < 7 V is 10% basic load is required

Innovative Energies Ltd  
1 Heremai Street, Henderson 0610  
Auckland, New Zealand  
Tel. (09) 835 0700 Fax (09) 837 3446  
<http://www.innovative.need.co.nz>  
E-Mail: [info@innovative.co.nz](mailto:info@innovative.co.nz)  
DIN EN ISO 9001 certified