

Dimensions: 500H x 495W x 245mm

CAB 150 DESCRIPTION

CAB150 comprises of a **SR250E12TFSL** boost charger, housed in a security cabinet with the back up battery in the bottom of the cabinet.

Originally designed for use on closed circuit TV and security alarm systems on bank premises but may be used in any situation requiring secure uninterruptible DC power.

A boost charger is used to ensure fast recharging of the battery after a mains power failure.

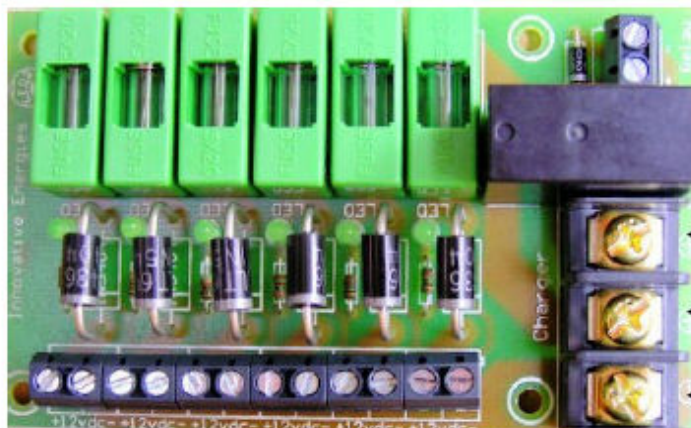
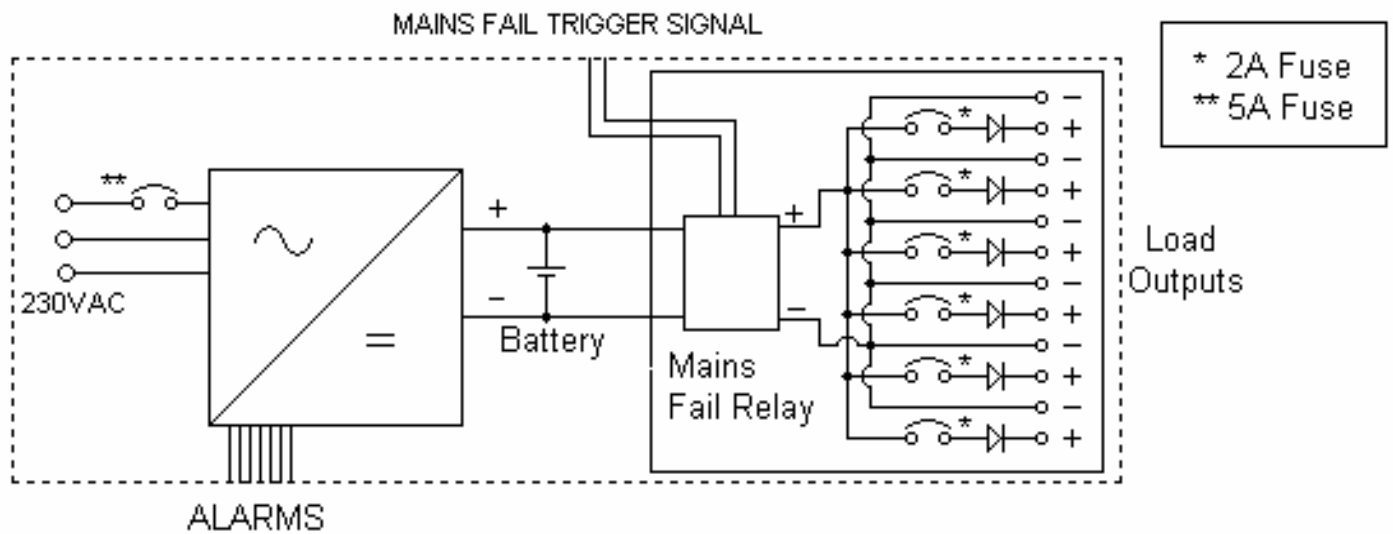

INPUT SELECTION DEPENDING ON INPUT TRIGGER

* Normally Close (N/C)

* Normally Open (N/O)

NEG INPUT

POS INPUT FROM CHARGER