

DCW100R SERIES

Rail DC/ DC Converters Single Output: 100 Watts



General Specifications

Input Voltage	24VDC (14.4 ~ 34) 36VDC (22 ~ 51) 48VDC (29 ~ 67) 72VDC (43 ~ 101) 96VDC (58 ~ 135) 110VDC (66 ~ 154)
	• Other voltages on request
Input Protection	Reverse polarity protection. Inrush current limiting Lower voltage than specified will not damage unit
Isolation	Input - Output 3000vdc Input – Chassis 1500vdc Output – Chassis 1500vdc
Efficiency	Model dependent , typically 80-90%
Output voltage	See tables
Output Power	100 watts
Voltage Adjust.	Customer specified
Immunity	EN50155 & EN50121-3-2 EN61000-4-2 ESD EN61000-4-3 RF Immunity EN61000-4-4 Fast Transients EN50155 Surge & Voltage variations EN61000-4-6 Conducted Immunity
EMI	EN5022 Class B Conducted & Radiated
Switching Freq.	47kHz ±5kHz
Regulation	±1% Line / Load combined
Dynamic Response	Max ±5% deviation for 10% - 50% load step with 1msec recovery
Ripple & Noise	Typically 1% pk-pk or 0.2% RMS of output voltage (20MHZ BW)
Overload Protection	Current limiting, with hiccup type short-circuit protection
Overvoltage Protection	Double regulator loop &Tranzorb across output
Operating Temp.	-25°C to +70°C cold plate temperature
Cooling	Conduction cooling / Convection cooling
Environmental Protection	Ruggedizing and Conformal coating of PCB.
Shock & Vibration	IEC61373 Cat 1 A & B and Cat 2
Humidity	5-95% non-condensing, higher ration option
MTBF	>150,000 hrs

Features

- Designed to rail standards EN50155 & EN50121
- Rugged design for on-board train applications
- Wide input voltage range
- Convection / Conduction cooled: No fans
- Fully isolated input – output 3000VDC
- Over voltage protection
- Overload and short circuit protection
- MTBF > 150,000hrs
- Special input / output combinations on request.

Description

The **DCW100R** series dc/dc converters are designed for use on Rail Rolling Stock and for many extremely harsh environments.

This rugged, industrial quality DC/DC converter uses a field proven topology to generate up to 100W continuous power, depending on the input/output configuration (i.e. efficiency).

It is a mature design with a track record in hundreds of applications. The series has large design headrooms and it is rated for operation over a -25 to +70°C temperature range.

It is cooled by conduction via baseplate to a heatsinking surface and by natural convection. These models are fully ruggedized and conformal coated for immunity to shock, vibration, humidity, moisture, dust and insects.

This chassis-mount design is optimized for low component count and high efficiency. The use of components with established reliability results in a high demonstrated MTBF.

Customized versions are also available.

Model	Input Options	Output Options		Power W
	V	V	A	
DCW100R	24V, 36V	12V	8A	100W
	48V, 72V	24V	4A	
	96V, 110V	48V	2A	
		110V	0.9A	

- Final part numbers will be factory allocated to reflect customer input & output requirements.
- Any output from 12-125V is possible.

LED / Indicator	Optional
Alarm output	Optional on some models
Connector	6 pole barrier-type terminal block with 3/8"spacing. (optional cover)
Dimensions	87 x 50 x 155mm (F0) W x H x L (includes terminal block & mounting flanges)
Weight	0.6kg

DCW100R SERIES

Rail DC/DC Converters Single Output: 50 ~ 100 Watts

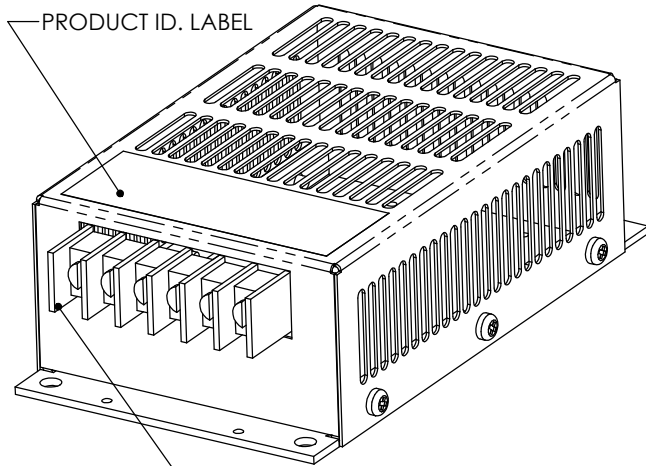

INPUT & OUTPUT CONNECTIONS
CURTIS 38000 SERIES 6 POLE BARRIER TYPE TERMINAL
WITH 6-32 UNC SCREWS

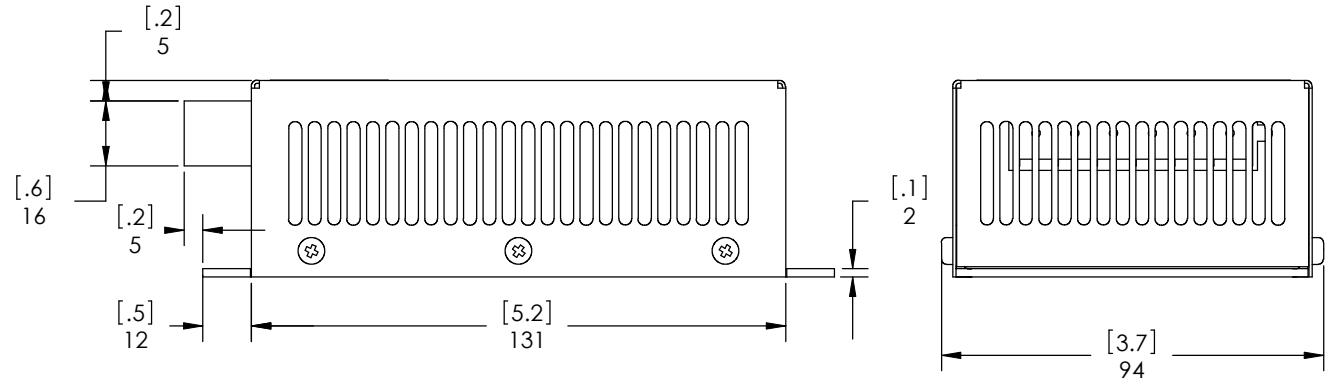
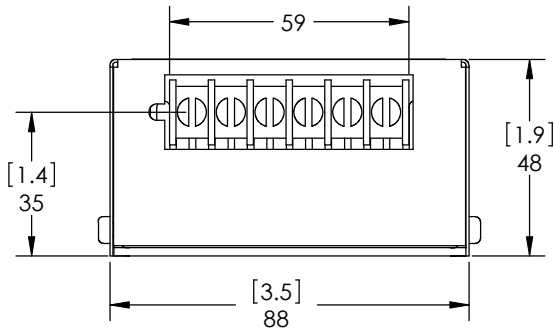
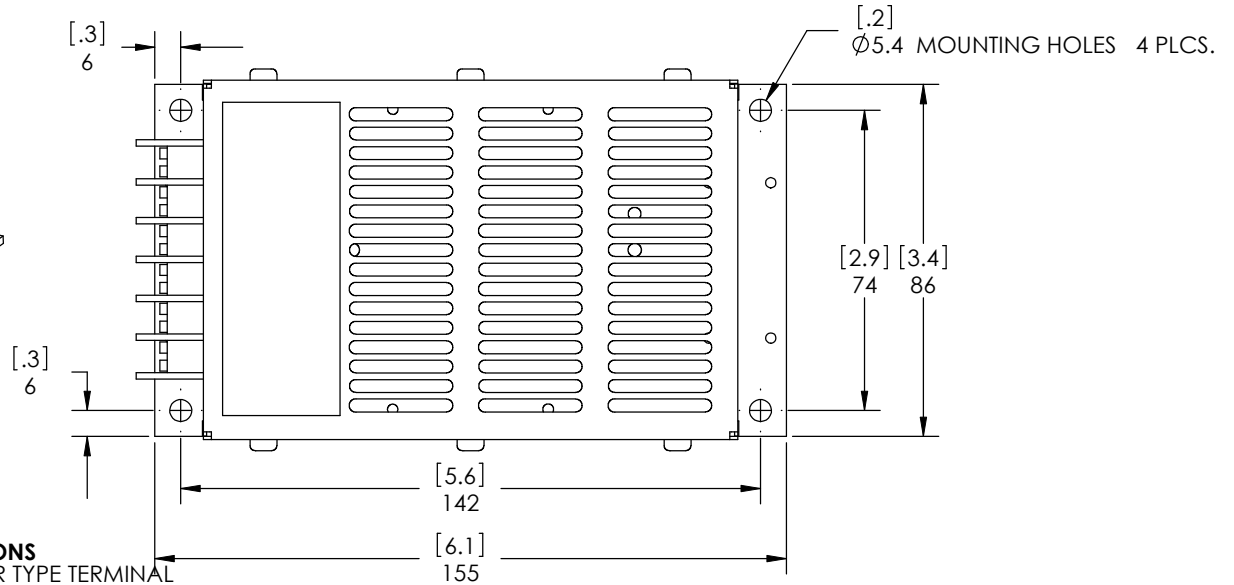

DIMENSIONS ARE IN MILLIMETERS
[INCHES] TOLERANCES ON
DECIMALS: XXX ± 0.2mm
XX ± 0.3mm
ANGLES: ± 2°
FRACTIONS: ± 0.4mm
UNLESS OTHERWISE STATED



Title: OUTLINE DRAWING

Part of: F0 PACKAGE