

User Manual

SE, SL

*No-Break™ DC UPS - Security series
35 - 150W*

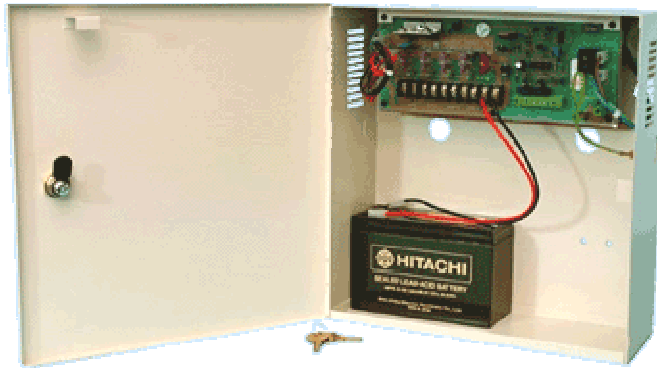

Safety

The user is responsible for ensuring that input and output wiring segregation complies with local standards and that in the use of the equipment, access is confined to operators and service personnel. A low resistance earth connection is essential to ensure safety and additionally, satisfactory EMI suppression (see below).

HAZARDOUS VOLTAGES EXIST WITHIN A POWER SUPPLY ENCLOSURE AND ANY REPAIRS MUST BE CARRIED OUT BY A QUALIFIED SERVICEPERSON.

Electrical Strength Tests

Components within the power supply responsible for providing the safety barrier between input and output are constructed to provide electrical isolation as required by the relevant standard. However EMI filtering components could be damaged as result of excessively long high voltage tests between input, output and ground. Please contact our technicians for advice regarding electric strength tests.

Earth Leakage

The EMI suppression circuits causes earth leakage currents which may be to the maximum allowable of 3.5mA.

Ventilation

High operating temperature is a major cause of power supply failures, for example it has been well documented that a 10°C rise in the operating temperature of a component will halve its expected life. Therefore always ensure that there is adequate ventilation for the equipment. Batteries and cooling fans also suffer shortened lifetimes if subjected to high ambient temperatures - both should be included in a routine maintenance schedule to check for signs of reduced efficiency.

Water / Dust

Every effort must be made in the installation to minimise the risk of ingress of water or dust. Water will almost always cause instant failure. The effects of dust are slower in causing failure of electronic equipment but all electrical equipment should be cleaned free of any dust accumulation at regular intervals. This is particularly important where internal fans are fitted.

Electromagnetic Interference (EMI)

Switching power supplies and converters inherently generate electrical noise. All wiring should be as short as practicable and segregated from all equipment wiring which is sensitive to EMI. Residual noise can be reduced by looping DC wiring through ferrite cable sleeves. These are most effective as close to the power supply as possible and as many turns of the wire taken through the core (+ and - in the same direction) as the core will accommodate.

Fuse ratings

Check that the wiring and fuses or MCBs match the rating of the PSU or converter. Adequate fuse protection of battery circuits is very important owing to the large potential currents available from batteries.

Connection polarity

It is critical to check the polarity carefully when connecting DC power supplies and chargers to equipment. Boost chargers and some float chargers usual have reverse polarity protection (RPP), which can be electronic (non-destructive) or by an internal fuse which needs to be replaced if a battery is connected in reverse.

Glossary of terms used in our user manuals

PSU = power supply unit

BCT = battery condition test

ECB = electronic circuit breaker

ELVD = electronic low voltage disconnect

RPP = reverse polarity protection

EMI = electromagnetic interference

SNMP = Simple Network Management Protocol

LAN = local area network

Check polarity before connecting batteries.

These power supplies/ chargers are designed to be used with batteries for correct operation.



- Uninterruptible *No-Break* DC Power Supply / battery back-up system
- Universal AC input: 85 - 264V
- Reverse polarity protection
- Alarms included as standard
- Electronic Low Voltage Disconnect
- Independent battery charge current limit
- Room for up to 4 x 7 Ah batteries
- 4 x separately fused load outputs
- 1 x fused battery output
- Designed for use with lead acid batteries
- 'Knockout' holes for top or bottom cable entry

◆ 24 Month Warranty

SPECIFICATIONS All specifications are typical at nominal input, full load and at 20°C unless otherwise stated.

ELECTRICAL	
Input	90 - 264VAC (47-63Hz) / 2.88 - 1.2A
Power Factor	>0.92
Fusing / Protection	Internal AC input fuse, DC output fuses
Isolation	1KV DC input / output to earth
Efficiency	≥ 87%
Output Power	75W & 150W
Output Voltages	13.8V , 27.6V
Voltage adj. range	85 - 105% of Vout
Charge Current Limit	Refer to model table
Line Regulation	+/-1%
Load Regulation	+/-2%
Over Volts Protection (OVP)	Yes, reset by power off

<i>No-Break</i> ™ FUNCTIONS AND ALARMS	
Reverse Polarity	Battery reverse connection will open internal fuse (and produce alarm)
Electronic Low Volts Disconnect (ELVD)	Disconnects battery when discharged, (10V for 12V systems, 20V for 24V systems)
Load Dump Jumper	Loads may be disconnected using external relay contact (jumper fitted ex factory)
Alarms	<ul style="list-style-type: none"> • Tamper switch activates when enclosure door opened • Power Fail¹ (alarms when float voltage drops to approx. 12.8V/25.6V) • Battery Low¹ (Battery volts = 11V/22V or reverse polarity)
Alarm Relay Contacts:	C - NO - NC full changeover rated 1A /50V DC, 32VAC
LED Indicators	<ul style="list-style-type: none"> • AC on • DC outputs OK • Battery fuse OK

PHYSICAL	
AC Input connector	Screw / clamp terminal block, (max 2.5mm ²)
DC Connections	Screw / Clamp 'barrier' terminal
Enclosure	White powder coated steel enclosure with locking door (lock & 2 keys included)
Battery Compartment	Takes up to four 7Ah batteries
Cooling	Convection
Weight	3.7 Kg

STANDARDS	
EMI	To EN55022:2006 Class B
Safety	To IEC950 / EN60950 / UL60950-1 / CSA

ENVIRONMENTAL	
Operating temperature	0 - 50 degC
Storage temperature	-10 to 85 °C ambient
Humidity	0 - 95% relative humidity non-condensing

75 & 150W Switch mode DC UPS in security enclosure



STANDARD MODEL TABLE (Suffix -S includes enclosure)

MODELS	Output Voltage (Load/Battery)	Max. Recomm. Load Current(A) *1	PSU Rated Current (A)	Charge Current Limit (A)	Power (W)
SE12/05S	13.8V	4.8	5.4	0.6 *2	75
SE12/10S	13.8V	9.5	10.8	1.3	150
SE24/05S	27.6V	4.1	5.4	1.3	150

NOTES: *1 to allow for adequate charging current for battery after mains failure
*2 may be set to 1.3A if specified at time of order

OPTIONS

Module only: Use suffix – C instead of -S
Enclosure only: Order code: SEC-MED



Module only

MOUNTING DETAILS / DIMENSIONS

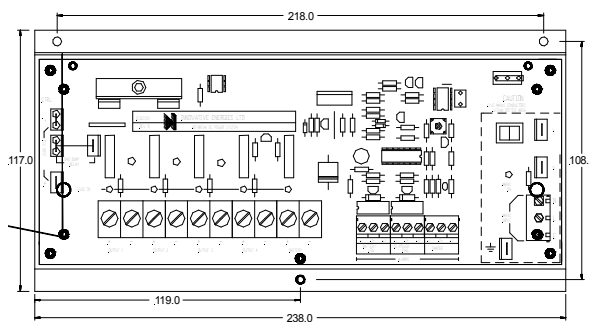
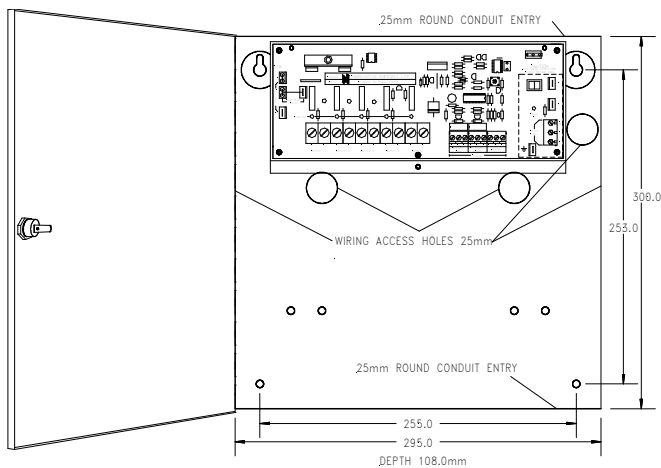

Enclosure: 306 H x 300 W x 108 D mm
Module: 238 L x 117 W mm

SYSTEM BLOCK DIAGRAM

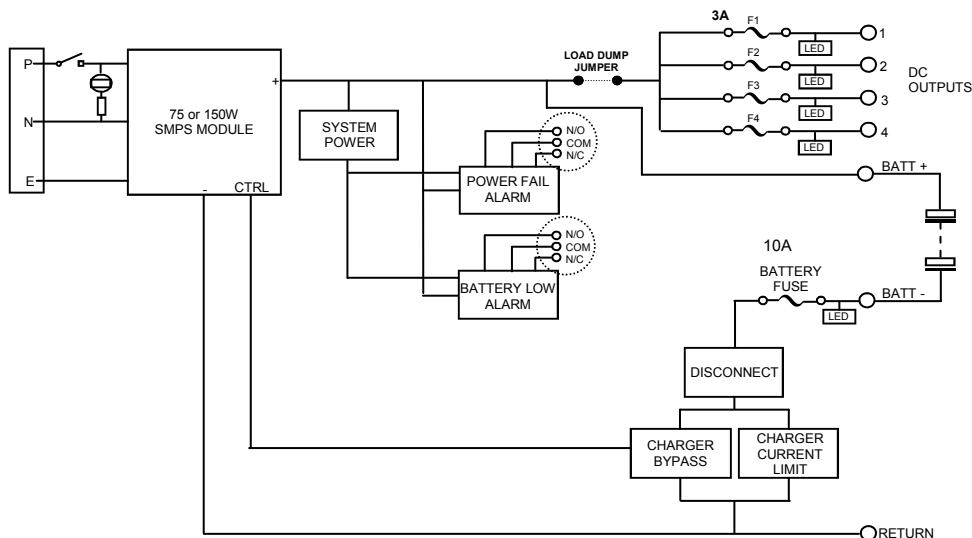



- Uninterruptible **No-Break™** DC Power Supply / battery back-up system
- Designed for security & access control uses
- Separately fused battery and load outputs
- Independent battery charge current limit
- Lockable enclosure
- Tamper alarm when door is opened
- Reverse battery polarity protection

SL 12/05S & SL12/10S only:

- Mains fail & Battery low (optional on 35W & 40W models)
- Low voltage disconnect to protect batteries
- No mains wiring required - can be installed by non-electrically registered personnel

* Note for NZ customers, these models are available only through Intek Security Group Ltd (Auckland, Wellington, Christchurch)

SPECIFICATIONS All specifications are typical at nominal input, full load and at 20°C unless otherwise stated.

ELECTRICAL	
AC Input	220-250 VAC, 50Hz , 0.4A
DC Outputs	2 x Load plus 1 x Battery, all fused with LED indication
Isolation	1KV DC input - output / earth
Output Voltages	13.8V or 27.6V as per model table
Current Limits	Refer to model table
Line Regulation	< 0.2% over input range
Load Regulation	< 0.5% open circuit to full load
Ripple	< 0.2% Pk-Pk, 0.05% RMS
Hold-up time	20ms
Operating Temp.	0°C to 50°C, max. 60°C at 50% load
Battery to Load Voltage Drop	0.3V max
<u>70W & 138W only:</u>	
Battery Low Voltage Disconnect	Set at 10V
Load Dump Jumper	A jumper is fitted on PCB but may be replaced with a user relay contact to disconnect loads from battery & PSU

STANDARDS	
EMI	To EN55022 Class A
Safety	EN60950, AS/NZS3260

CONNECTIONS	
AC Input Connection	35W & 40W: Hard wired 70W & 138W: IEC 320 connector with 3 Pin NZ/Aust plug
DC Output	Barrier terminals

FUNCTIONS AND ALARMS	
Reverse Polarity	Battery reverse connection will open battery fuse (and produce alarm)
Alarms (Mains fail & Battery low standard for 70W & 138W, optional extra for 35W & 40W)	<ul style="list-style-type: none"> • Tamper switch activates when enclosure door opened • Mains Fail¹ (also detects PSU fail) • Battery Low (set at 11V)
¹ Contact ratings	NO - NC full changeover rated 1A /50V DC, 32 VAC
Indicators	Green LEDs on when fuses OK

PHYSICAL	
Enclosure	White powder coated steel enclosure with locking door (lock & 2 keys included)
Dimensions	35W & 40W: 295 H x 280 W x 76 D 70W & 138W: 335 H x 342 W x 135 D
Weight (with enclosure)	35W & 40W: 4kg 70W: 6.3 kg 138W: 8.2 kg
Mounting	Wall mount via 2 x keyholes at top rear of enclosure plus 2 holes at bottom
Battery Compartment	Takes up to 4 x 7Ah or 2 x 12Ah batteries
Cable Entry	"Knockout" holes top and bottom, 25mm diameter and 25mm square/20mm diam.



SL 12/2.5S & SL 24/1.5S

35 - 138 Watt Linear DC UPS in security enclosure



STANDARD MODEL TABLE (Suffix -S includes enclosure, use -C for module only)

MODEL CODES	Output Voltage (V)	Max. Recomm. Load Current (A)	Charge Current Limit (A)	PSU Rated Current (A)	Power (W)	Mains Fuse (A)	Load Fuses (A)	Battery Fuse (A)
SL 12/2.5S	13.8	2.0	0.5	2.5	35	1	1	1
SL 24/1.5S	27.6	1.1	0.4	1.5	40	1	1	1
SL 12/05S	13.8	2.6	1.2	3.8	70	3	5	10
SL 12/10S	13.8	6	2.0	8.0	138	3	10	20

OPTIONS

Alarms for SL12/2.5 & SL24/1.5

- Mains Fail
- Battery Low (set at 1.83V / cell)

2 x Relay outputs –clean changeover contacts rated 1A /50V DC, 32VAC

Module only

Specify suffix -C instead of -S

NOTE

A battery must be connected for loads such as motors and incandescent lamps which are low resistance on start up.

SYSTEM BLOCK DIAGRAMS

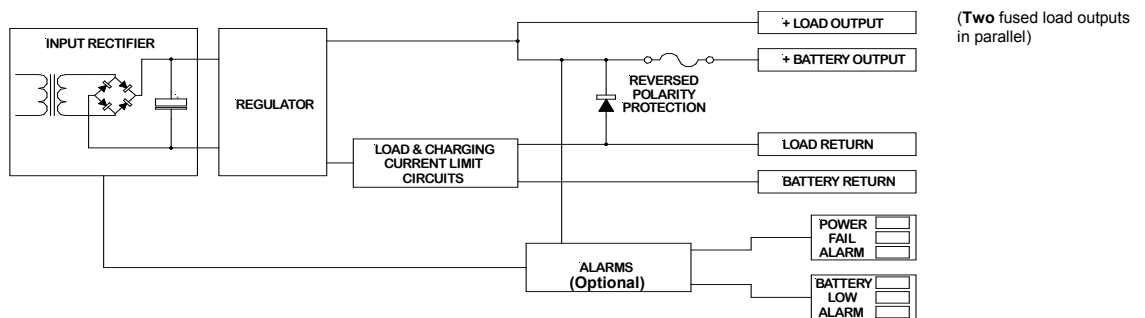

SL 12/2.5S
SL 24/1.5S

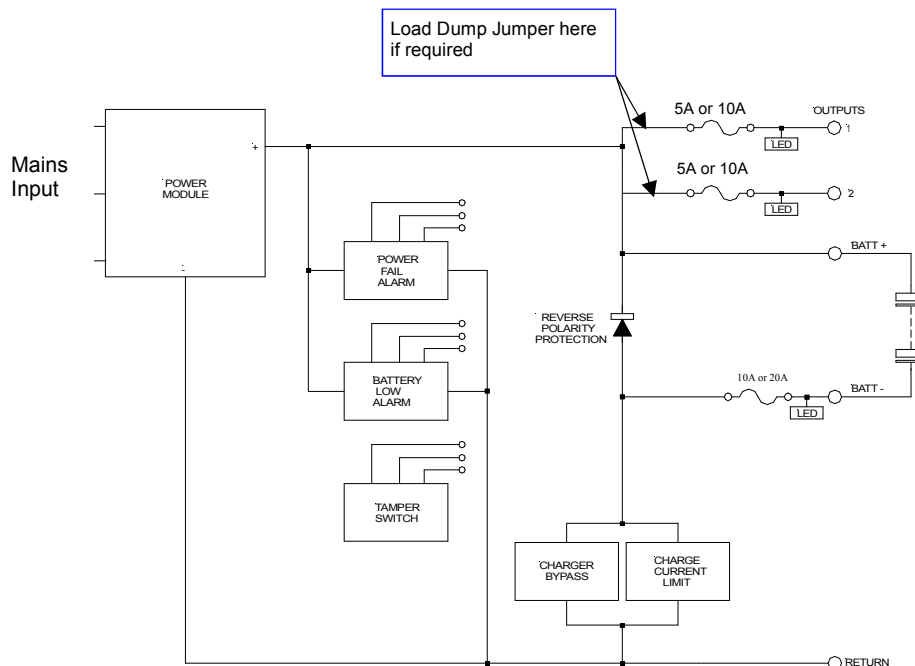

SL 12/05S
SL 12/10S

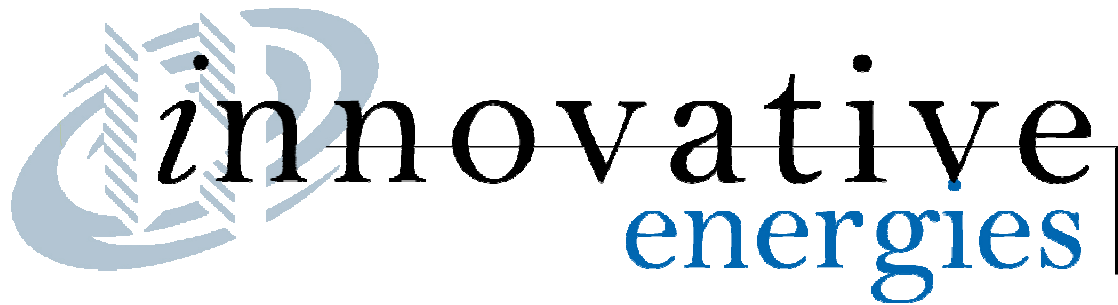

TERMS OF WARRANTY

Innovative Energies Ltd warrants its power supplies for 24 months (two years) from date of shipment against material and workmanship defects.

Innovative Energies' liability under this warranty is limited to the replacement or repair of the defective product as long as the product has not been damaged through misapplication, negligence, or unauthorized modification or repair.

Thank you for purchasing from Innovative Energies.

We trust your power supply will exceed your expectations and perform for years to follow.

Sincerely,
The Innovative Energies team.

Innovative Energies Limited

Phone: +64 9 835 0700
Freephone: 0800 654 668 (New Zealand)
1800 148 494 (Australia)
Fax: +64 9 837 3446
Email: info@innovative.co.nz
Online: www.innovative.co.nz
In Person: 1 Heremai Street, Henderson, Auckland, New Zealand
By Post: PO Box 19-501, Auckland 1746, New Zealand