



Fast and Safe Recharging for lead acid batteries

◆ 24 Month Warranty

- Fully automatic operation
- Designed to industrial standards
- Automatic temperature compensation
- Indefinite short circuit protection
- Operating state and fault indication
- Non-destructive reverse polarity protection
- Can safely be left permanently connected to battery, will maintain 'float' charge
- Fully programmable microprocessor control
- ISO9001 Design management system
- Fully designed and manufactured in NZ

The **SR SmartCharger** is designed to recharge your battery in the shortest practicable time with programmable parameters to suit your specific application.

SPECIFICATIONS All specifications are typical at nominal input, full load and at 20°C unless otherwise stated.

ELECTRICAL	
Input - standard optional	180 - 264V, 45-65Hz 88 - 132V 45-65Hz or 110-180VDC
Fusing / Protection	Internal fuse
Output Protection	Automatic shutdown if battery leads reversed
Current Limit	Constant current limit on overload & short circuit
Isolation	1KV DC input - output / earth
Efficiency	≥ 85%
Inrush current	<30A, 1.8ms
Output Power	100W
Output Voltages	Refer model table
Voltage adj. range	Approx 95 - 105% of V nominal
Temp. Compensation	Output voltage compensated at -4mV / °C / cell
Line Regulation	<0.04% over input range
Load Regulation	<0.5% open circuit to 100% load
Noise	<0.3%
Transient response	200mV over / undershoot, load step 20-100%, 400us settling time
Hold-up time	15 - 20 ms (nom. - max. Vin) without battery
OVP	Over-voltage protection on output at ~ 130% of nominal output voltage

STANDARDS	
EMI	to CISPR 22 / EN55022 class A
Safety	to IEC950 / EN60950 / AS/NZS3260

FEATURES	
LED Indication	BOOST: Red FLOAT: Green
Factory programmable parameters	- Start up in boost mode (Boost) - Current terminated boost (Yes, at 10% rated current) - Current initiated boost (Yes) - Start in boost on mains return (Yes) - Pre-boost state timer (1 minute) - Max boost charge time (24 hours) - Pre-float state timer (1 minute) - Resume prior state upon mains return timer (10 minutes) - Resume on boost charge upon mains return (24 hours) - Delay before mains fail recognition (5 mins)
(default settings shown in brackets; please note that some parameters are interdependent of each other)	

PHYSICAL	
AC Input Connection	IEC320 socket (NZ power cord supplied)
DC Output Connection	Plug-in socket & with screw terminals
Enclosure	Zinc plated steel base/ powder coated lid
Temperature sensor	1.7m lead with adhesive pad
Mounting	Brackets for permanent fixture
Weight	0.94Kg
Dimensions	146.5W x 177D x 62H mm

ENVIRONMENTAL	
Operating temperature	0 - 50 °C ambient at full load De-rate linearly >50 °C to no load @ 70 °C
Storage temperature	-10 to 85 °C ambient
Humidity	0 - 95% relative humidity non-condensing
Cooling	Natural convection

100 Watt Three Stage Smartcharger (boost charger)

SR100B

STANDARD MODEL TABLE

MODELS	Output Voltage ¹ (float)	Output Voltage ¹ (boost)	Output Current (A)	Battery Size ² (Ah)
SR100B12	13.8	14.7	6.7	24 - 70
SR100B24	27.6	29.4	3.3	12 - 40
SR100B30	34.5	36.7	2.7	10 - 30
SR100B36	41.4	44.1	2.2	9 - 25
SR100B48	55.2	58.8	1.7	6 - 20

¹ May be adjusted to suit battery specifications
² Check manufacturer's recommendations

MOUNTING DETAILS / DIMENSIONS

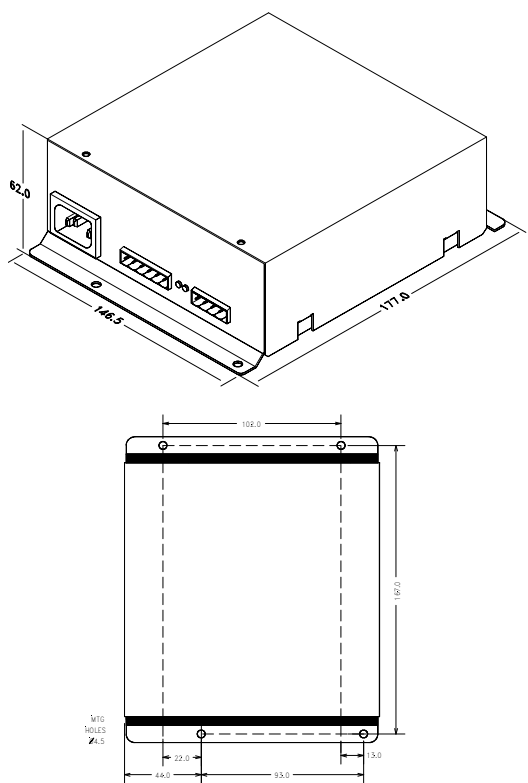

OPTIONS

Alarms Not available with this model

Adjustable Parameters All firmware parameters listed under features may be adjusted at time of ordering

MOUNTING OPTIONS

Rack mount 2RU x 19" rack - (rear connection)
Code: **SR-RM2U**

Wall mount enclosure Code: **SEC-SR**

For full information on these options please refer to respective data sheets.

WARNING

If the SmartCharger is connected to operating equipment during charging:

- equipment will be subjected to 1.22 times the nominal voltage.
- the standing load must be taken into account for the correct operation of the charger. Please contact our sales office if you have any standing load.

MODEL CODING AND SELECTION CHART

SR100B 12 T X G

