

User Manual

SR100i....232 or LAN

*No-Break™ DC UPS with communications port
100W*



Safety

The user is responsible for ensuring that input and output wiring segregation complies with local standards and that in the use of the equipment, access is confined to operators and service personnel. A low resistance earth connection is essential to ensure safety and additionally, satisfactory EMI suppression (see below).

HAZARDOUS VOLTAGES EXIST WITHIN A POWER SUPPLY ENCLOSURE AND ANY REPAIRS MUST BE CARRIED OUT BY A QUALIFIED SERVICEPERSON.

Electrical Strength Tests

Components within the power supply responsible for providing the safety barrier between input and output are constructed to provide electrical isolation as required by the relevant standard. However EMI filtering components could be damaged as result of excessively long high voltage tests between input, output and ground. Please contact our technicians for advice regarding electric strength tests.

Earth Leakage

The EMI suppression circuits causes earth leakage currents which may be to the maximum allowable of 3.5mA.

Ventilation

High operating temperature is a major cause of power supply failures, for example it has been well documented that a 10°C rise in the operating temperature of a component will halve its expected life. Therefore always ensure that there is adequate ventilation for the equipment. Batteries and cooling fans also suffer shortened lifetimes if subjected to high ambient temperatures - both should be included in a routine maintenance schedule to check for signs of reduced efficiency.

Water / Dust

Every effort must be made in the installation to minimise the risk of ingress of water or dust. Water will almost always cause instant failure. The effects of dust are slower in causing failure of electronic equipment but all electrical equipment should be cleaned free of any dust accumulation at regular intervals. This is particularly important where internal fans are fitted.

Electromagnetic Interference (EMI)

Switching power supplies and converters inherently generate electrical noise. All wiring should be as short as practicable and segregated from all equipment wiring which is sensitive to EMI. Residual noise can be reduced by looping DC wiring through ferrite cable sleeves. These are most effective as close to the power supply as possible and as many turns of the wire taken through the core (+ and - in the same direction) as the core will accommodate.

Fuse ratings

Check that the wiring and fuses or MCBs match the rating of the PSU or converter. Adequate fuse protection of battery circuits is very important owing to the large potential currents available from batteries. Our **No-Break DC** series has an internal ECB for protection of the battery circuit but for all other charging situations should have an external fuse or circuit breaker fitted in the battery circuit.

Connection polarity

It is critical to check the polarity carefully when connecting batteries and equipment to DC power supplies and chargers. Boost chargers (and some float chargers) made by Innovative Energies have reverse polarity protection, which can be by an electronic switch (non-destructive) or an internal fuse which needs to be replaced if a battery is connected in reverse.

Glossary of terms used in our user manuals

PSU = power supply unit

BCT = battery condition test

ECB = electronic circuit breaker

ELVD = electronic low voltage disconnect

RPP = reverse polarity protection

EMI = electromagnetic interference

SNMP = Simple Network Management Protocol

LAN = local area network

INTRODUCTION

The **No-Break™ DC** power supply is designed to provide DC power to lead acid batteries for critical back up applications. In addition to the normal features of the standard **SR100C..** model, the **SR1000i...** has a communication interface to enable user monitoring of the power supply and battery parameters and control of the battery condition test function. This user manual refers only to the RS232 and Ethernet (ASCII code) versions.

No-Break™ SYSTEM BLOCK DIAGRAM

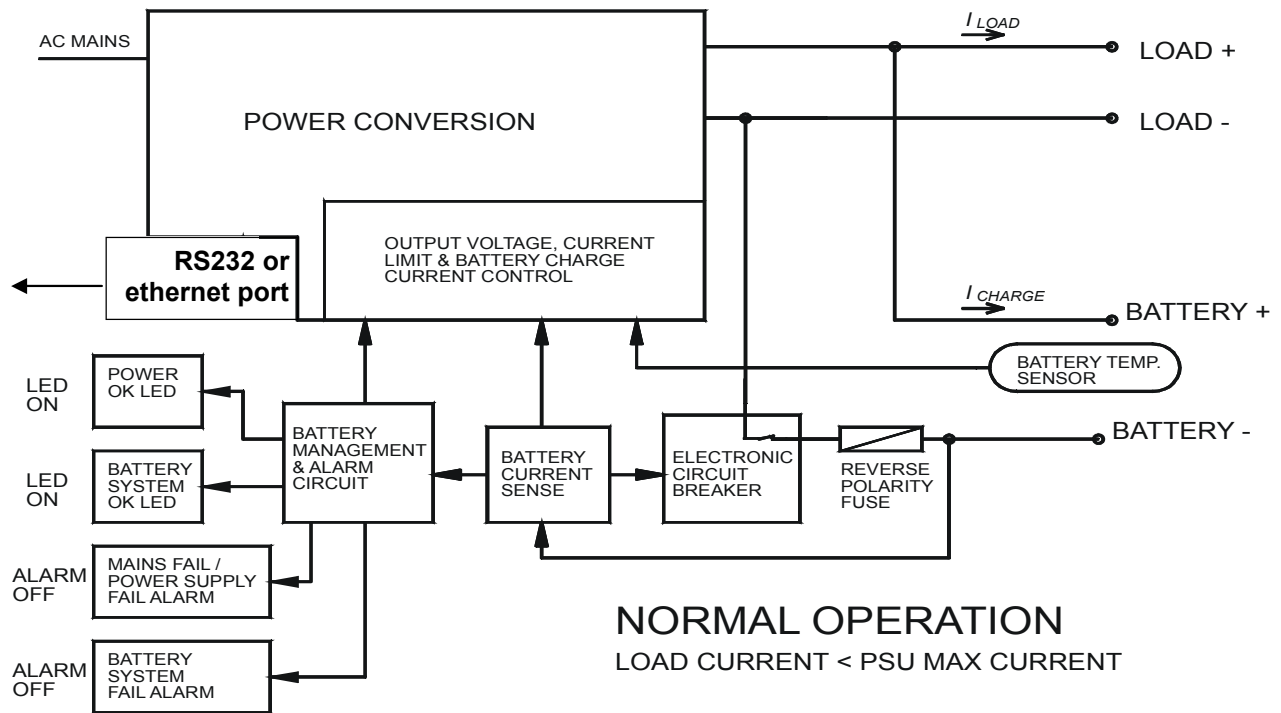

OPERATION OF ELECTRONIC CIRCUIT BREAKER (ECB) FOR PROTECTION OF BATTERY CIRCUIT

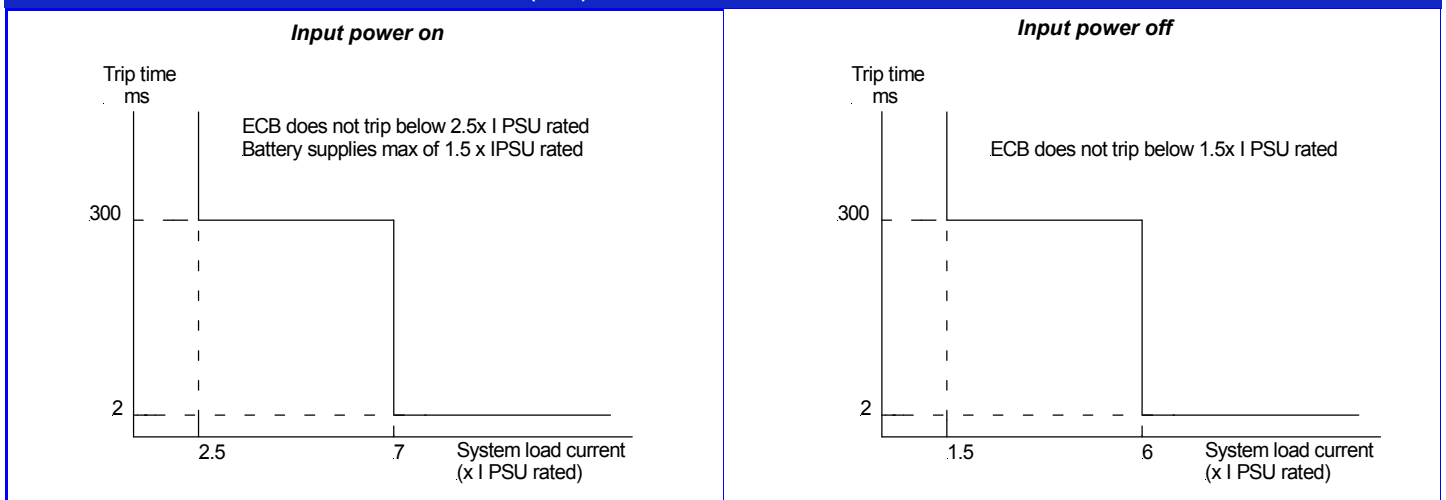

The ECB is activated under the following conditions:

1. battery voltage drops below the V_{disco} (1.66V/cell)
2. battery current overload (refer to graphs above)

The ECB will latch open only when there is no input power present. It will reset when input power is restored or can be manually reset by briefly shorting the **BAT-** and **LOAD-** terminals together when there is no input power.



SR100 *i* with LAN communication port

◆ 24 Month Warranty

- **Separate outputs for load and battery**
- **Battery detection - regular battery presence and battery circuit integrity checks**
- **Deep discharge protection**
- **Independent load and charge current limits**
- **Overload, short circuit & reverse polarity protect**
- **Automatic temperature compensation**
- **Automated or manually controlled battery condition test**
- **No transition switching to backup battery**
- **Alarm contacts & LEDs for precise fault indication**
- **ISO9001 Design management system**
- **Suitable for use with all types of lead acid batteries (batteries external to power supply)**

SPECIFICATIONS All specifications are typical at nominal input, full load and at 20°C unless otherwise stated.

ELECTRICAL

Input Voltages	
▪ standard	180V - 264VAC 45-65Hz
▪ optional	88V - 132VAC 45-65Hz
Fusing / Protection	AC input fuse DC battery output fuse
Isolation	1KV DC input - output / earth
Efficiency	≥ 85%
Inrush current	<30A, 1.8ms
Output Power	100W continuous (0 - 50°C)
Output Voltages	13.8V, 27.6V, 41.4V, 55.2V Other voltages by request.
Voltage adj. range	85 - 105% of Vout
Temp. Compensation	Temperature sensor on 1.7m lead with adhesive pad: -4mV / °C / cell ±10%
Current Limit	Output current limit set at rated FLC
Line Regulation	<0.04% over AC input range
Load Regulation	<0.5% open circuit to 100% load
Noise	<0.3%
Transient response	200mV over / undershoot, load step 20-100%, 400us settling time
Thermal Protection	Automatic current de-rating if >50°C. Self-resetting.
Hold-up time	15 - 20 ms (nom. - max. Vin) without battery

STANDARDS

EMI	to CISPR 22 / EN55022 class A
Safety	to IEC950 / EN60950 / AS/NZS3260

No-Break™ FUNCTIONS AND ALARMS

Battery Charge Current Limit	See Model Table for default settings. (25% & 50% settings available on request)
Reverse Polarity	Battery reverse connection will open internal fuse (and produce alarm)
Battery Monitoring	Detects for presence of battery on start up, then every 60 minutes when charge current < 200mA
Battery Protection	Electronic Circuit Breaker (ELCB) operates under the following conditions:
- battery discharged	ELVD (electronic low voltage disconnect) activates when battery voltage drops to 1.67V/cell (adjustable) - auto reset
- overload	Allows ~150% load from battery without acting, operates within 300ms for total load > 600%
- short circuit	Acts within 2ms, backed up by fuse
LED Indication	Green: Power OK Green: Battery OK
Alarms	<ul style="list-style-type: none"> • Power OK (Mains/PSU fail) • Battery System OK - alarms when battery voltage low (on mains fail), battery missing, battery circuit wiring faulty, BCT fail (if enabled)
Alarm Relay contacts	C - NO - NC full changeover rated 30VDC, 2A / 110VDC, 0.3A / 125VAC, 0.5A
Battery Condition Test (BCT)	Standard on SR100i : default setting = 20mins every 28days

PHYSICAL

AC Input connector	IEC320 input socket (similar to PCs etc.)
DC Connections	Plug-in style socket & mating screw terminal block: (max. wire 2.5mm ² / way)
Alarm Connections	Plug in screw terminal block
Enclosure	Zinc plated steel / powder coated lid
Dimensions	147W x 177D x 62H mm
Weight	0.95 Kg

100 Watt No-Break™ DC UPS with comms. interface

SR100i

STANDARD PREFERRED MODEL TABLE

MODELS	DC Output			
	Output Voltage (Load & Charger)	Max. Recomm.*1 Load Current (I _{LOAD})	Charge Current limit*2 (I _{CHARGE})	PSU Rated Current (I _{PSU})
SR100i 12	13.8V	6.0A	7.5A	7.5A
SR100i 24	27.6V	3.0A	3.7A	3.7A
SR100i 36	41.4V	1.9A	2.4A	2.4A
SR100i 48	55.2V	1.5A	1.9A	1.9A

*1 to allow for adequate charging current

*2 25% & 50% settings available on request

ENVIRONMENTAL

Operating temperature	0 - 50 °C ambient at full load De-rate linearly >50 °C to no load @ 70 °C
Storage temperature	-10 to 85 °C ambient
Humidity	0 - 95% relative humidity non-condensing

ACCESSORIES SUPPLIED

Mounting Feet together with screws
AC power cord Standard 1.5m lead with IEC320 socket / local plug
DC connector with mating screw-terminal plug
Alarm connector with mating screw-terminal plug

OPTIONS

Communication Port for -i & V versions	Choice of RS485, RS232, Ethernet/LAN
+PROTOCONMB-x	Protocol Converter (RS485 to MODBUS) with programming port for PC. Power MBLink setup software supplied -x = blank x = -OE for above plus Ethernet Port
Parallel Redundancy	Use 15A output diode assembly, Code: +P15



SR100i with RS485 comms port

CABINET OPTIONS

19" Rack Mount	2U sub rack option: add SR-RM2U Optional V/I meter for subrack: SR-METER
Wall Mount Enclosure	PSU may be fitted into enclosure with MCBs and terminals. Code: SEC-SR

MODEL CODING AND SELECTION CHART

SR100i12 T X G-232	Optional Communication Interface Port	485 = RS485 232 = RS232 LAN = ETHERNET Blank = no comm. port
Input voltage	230V AC = blank 110V AC = G	
Phoenix combicon plug-in terminal block		
Temperature Compensation:	Yes = T No = blank	
DC output: Nominal battery voltage:	12, 24, 36, 48	
Function:	C = No-Break™ i = No-Break™ with comms interface	

Installation Instructions

CONNECTION DIAGRAM

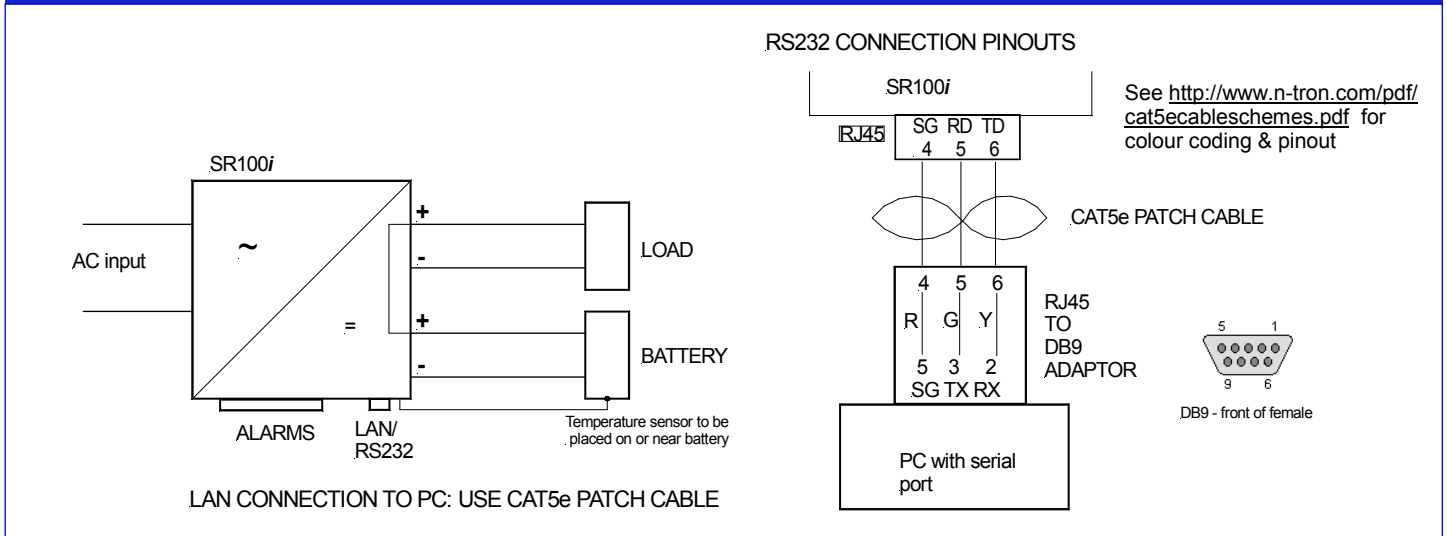

CONNECTION & INITIAL TESTING

- 1 Check input and output voltages of system, ensure that they match the equipment. All loads should be isolated.
- 2 Check polarity of all wiring. Place temperature sensor probe near or on batteries.
- 3 Plug in ac input and turn power on. Both LEDs will light up after approx. 4 sec, **“BATTERY”** LED will go out after another 10 sec (since there is no battery connected). DC output voltage should appear at both load and battery outputs (ensure screws are tightened down on the connector block).
- 4 Turn off input power.
- 5 Connect battery.
- 6 Check that ELCB (internal electronic circuit breaker) closes by shorting together the **BATTERY –ve** and **LOAD –ve** terminals briefly. You will hear a relay operate and both LEDs will light up. If this does not happen, there is a fault in the wiring or the internal battery protection fuse is ruptured (see Note 2 below). The battery voltage will then appear at the load terminals and the **“BATT”** alarm relay energises. The **“POWER”** LED stays on for about 30 seconds.
- 7 Connect load wiring to **LOAD+** and **LOAD-** terminals.
- 8 Turn on ac power.
- 9 After the batteries are fully charged, check that the battery continues to power up the load when the input power is turned off.
- 10 Connect communication port to router, PC or other suitable device. Please refer to page 8 for instructions for the LAN communication set up procedure. Use a direct connection for RS232 as shown above.

NOTES

1 Current ratings

Note that the system is capable of delivering a maximum of 2.5 x rated PSU current to the load.

2 Reverse polarity protection

If the battery is connected in reverse, the internal battery protection fuse may be ruptured and the unit should be returned to the manufacturer for repair. If the fuse is good, the voltage measured as at step 3 above should be exactly the same on both the load and battery outputs.

3 Battery condition test (BCT) fail reset

If the system fails a battery condition test the BATT LOW alarm latches (de-energized state) until either: both the mains power input and the battery are disconnected briefly
or: the system passes the next BCT.

ALARM CONNECTIONS

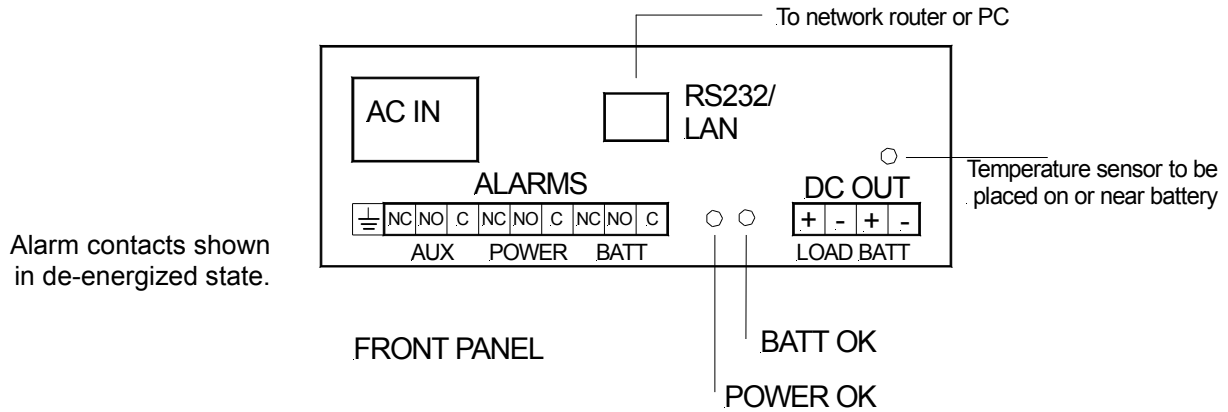

ALARMS

POWER:

De-energized on loss of mains input power

NOTE: 30 second delay

BATT:

De-energized when either:

1. battery voltage = 1.8V/cell (for 2V cells) - operates only when no mains power present or
2. battery missing or fault in battery circuit wiring (alarm does not activate for up to battery detection interval time).

AUX:

This relay is energized when BCT is in progress unless otherwise requested.

LED INDICATION

Power OK LED	Battery OK LED	Power Alarm	Battery Alarm	Condition
		Normal	Normal	System Normal: Input power on, battery circuit is OK
		Normal	Normal	Battery detection test in progress
		Normal	Alarm	Input power on, battery system fault: 1. Internal battery fuse has opened or 2. Battery circuit wiring open circuit, battery missing, ECB has tripped
		Alarm	Normal	Input power off, battery system is OK (battery volts > Vbatl)
		Alarm	Alarm	Input power off and battery has discharged to $\leq V_{batl}$
		Alarm	Alarm	Input power off, ELVD has activated and disconnected battery from load.
		Normal	Normal	BCT is in progress: LEDs flash slowly
		Normal	Alarm	Input power on, failed previous BCT - battery voltage < Vpres during the BCT

LEGEND :

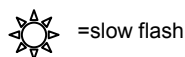
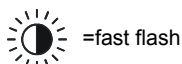
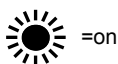

Parameter	Nominal Voltage					Default Value
	12V	24V	30V	36V	48V	
*1 V out = Output Voltage	13.8	27.6	34.5	41.4	55.2	2.3V/cell
*2 V pres = Voltage threshold for battery detection & battery condition test (BCT). If voltage drops to this level during BCT then the test is aborted and BATT SYS OK alarm activated.	12.2	24.4	30.5	36.6	48.8	2.03V/cell
*2 V shudt = Output voltage of PSU during battery detection & BCT	11.5	23	28.8	34.5	46	1.92V/cell
*2 V batl = voltage where BATT low alarm activates during mains fail	11	22	27.6	33	44	1.84V/cell
*2 V disco = Battery disconnect level on low voltage during mains fail	10	20	25	30	40	1.66V/cell
*2 Bccl = Maximum charge current as % of rated PSU rated current						100%
*2 Comms = communications mode of PSU: F = continuous data stream of status M = responds only to request made by a controller						F
*3 BatDetect = Battery detection interval time, active only when no battery charge current is detected (the unit may not detect a missing battery for up to this time)						60 min
*3 BCT = length of battery condition test						20 min
*3 Ret = retest option: N = after a failed BCT further scheduled BCTs are inhibited Y = after a failed BCT further scheduled BCTs will be allowed						Y
*3 CC = Length of charge cycle in minutes/hours/days. ie. time between battery condition tests						40m/23h/027d
*3 MfiBCT = time before mains fail check during BCT. A mains fail during a BCT will stop the BCT. If set longer than BCT time no mains fail check will occur.						030 min

NOTES:

- *1 Output voltage is set by an internal potentiometer on the printed circuit board.
- *2 These parameters are user adjustable. Please contact your supplier for further information.
- *3 These parameters are factory set. Please contact your supplier for further information if you require these to be altered.

BATTERY CONDITION TEST

The BCT function may be enabled to be automatically scheduled on start up by an internal jumper. Refer to the photo to the right for the position of this jumper. This jumper is not fitted unless specified on order as the BCT function may be enabled/disabled via the communication port.

If the jumper is not fitted and the system loses power completely, the automatic BCT will be disabled on start up until activated by the user.



BASIC INSTRUCTIONS FOR SETTING UP COMMUNICATIONS PORT

1.0 **RS232 port:** Go to Step 2.3 in the following instructions.

2.0 **LAN port:**

To use the LAN port you will need to install the Lantronics Device Installer (v 4.3.0.2) and Com Port Redirector (v 4.3.0.1), or similar software. The Lantronics software may be downloaded from:

<http://www.lantronix.com/device-networking/utilities-tools/device-installer.html>

<http://www.lantronix.com/device-networking/utilities-tools/com-port-redirector.html>

2.1 Run device installer programme

The device installer programme will detect the power supply if your system is able to automatically allocate a compatible IP address. If device is unreachable, use the 'Assign IP' function.

2.2 Run Comm. Port Redirector/ Configuration programme

Key "Add IP"

Host: type in the IP address your system has allocated, eg. 192.168.100.31

Select Com. port to be redirected, eg. "COM 4"

Set "TCPPort" = "10001"

Port Settings: Tick "Raw Mode"

Save your settings.

2.3 Run MS Terminal or Hyperterminal or any suitable programme to enable you to view the serial data from the power supply.

2.4 Set up a new connection.

Connect using the virtual port as set up in the redirector programme, eg. "COM 4".

Use the following port settings:

Bits/second: 9600

Databits: 8

Parity: None

Stop bits: 1

Flow control: Hardware

Key "OK", the following is a typical data line which will be displayed:

/ CC B? Vout:13.4V Ibat: 00.0A Ipsu:01.4A + 22°C 0A Ipsu:01.4A + 22°C

POWER SUPPLY DATA CODES

USER CONTROLS ("Caps Lock" on)

Key Stroke	Response
"2"	Displays configuration data
"D"	Displays status info (not applicable if in "F" comm. Mode)
"F"	Displays voltage, current & temperature (not applicable if in "F" comm. Mode)
"G"	Start BCT
"H"	Stop BCT
"I"	Enable scheduled BCT
"J"	Disable scheduled BCT
"K"	Report if scheduled BCT is enabled or disabled

Explanation of data codes

All data is transmitted as direct readable ASCII code.

Typical Screen View:

```
IEL NB5sys.V13 SR100i12T
s/n: 0025 6666 BatDetect:060m
Vpres(1):12.0V Vshutd(2):11.5V
Vbatl(3):11.0V Vdisco(4):10.0V
Bccl(ABC):100% BCT:020m Ret:Y
Comms(MF):F CC:40m 23h 027d
MfiBCT:090m
- CC BM Vout:13.5V Ibat:-00.0A Ipsu:01.4A + 20C
```

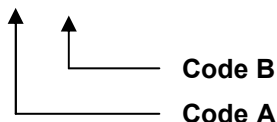

Code A

CC – charge cycle (normal operation)
MF – mains fail (system on battery power)
OL – system overloaded, output voltage is below Vpres setting
BCT – battery condition test is in progress

Code B

M? – possible mains fail, i.e. no mains detected but brown out timer not expired (30sec)
m? – same as above, but has failed the previous BCT
BP – battery present, system OK
bP – same as above, but has failed the previous BCT
B? – No battery charge current detected, up to the next scheduled battery detection, uncertainty about the presence of the battery exists.
b? – same as above, but has failed the previous BCT
BM - battery is missing, the battery detection routine did not find a battery to be present. This will also reset the 'battery condition not good' of a failed BCT.
BO – battery is in 'OK' state during mains fail
bO – same as above, but has failed the previous BCT
BL – battery is in 'LOW' state during mains fail
bL – same as above, but has failed the previous BCT
SD – system will shut-down if no mains present and output voltage stays below Vdiscon for 30seconds.

Displayed values following Code B

Vout = output voltage of PSU
Ibat = charging current
Ipsu = total output current
+20°C = temperature measured by temp. sensor

#1 1 x No-Break™ DC charger and 1 x battery bank

This is the basic connection which is most commonly used, and provides adequate protection for the majority of systems requiring DC back up in the event of a mains power failure.

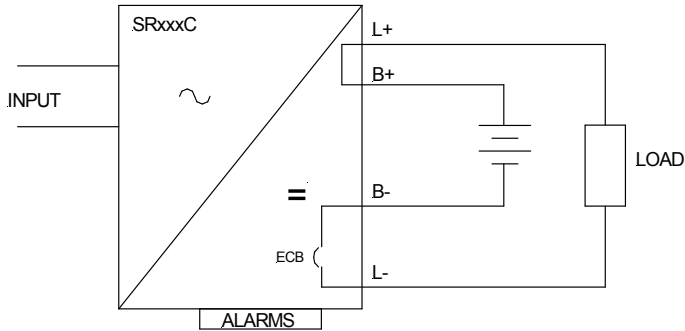

Single battery DC backup system

Alarms Available

Power OK	YES
Battery Missing	YES
Battery Low	YES
Battery Condition Test Fail	YES

#2 1 x No-Break™ DC charger and 2 x battery banks

The **SR250xxxV No-Break™ DC** UPS is designed to provide superior battery backup availability without having to use two power supplies. Dual battery banks and automatic battery condition testing reduce the risk of battery failure for critical applications.

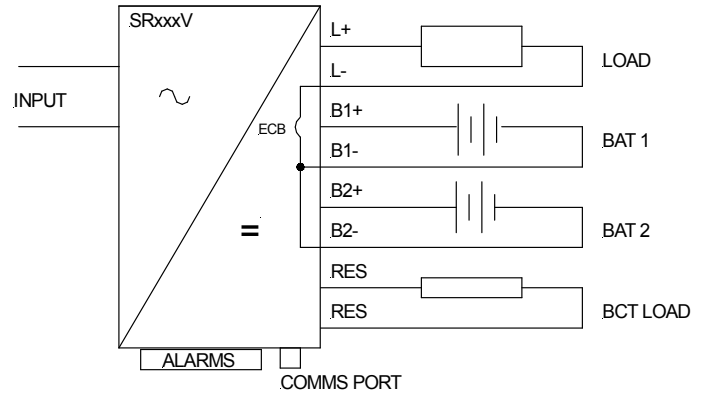

N+1 redundancy for batteries

Alarms Available

Power OK	YES
Battery Missing (B1&B2)	YES
Battery Low (B1&B2)	YES
Battery Condition Test Fail (B1 & B2)	YES

#3 2 x No-Break™ DC chargers and 2 x battery banks

2 x No-Break™ DC chargers connected in parallel with separate battery banks & output diodes. This solution provides an extremely high level of redundancy for very critical applications, with redundancy of the battery in addition to the power supply. The diodes isolate the units from one another in the event of a short circuit appearing at the other output and aid current sharing.

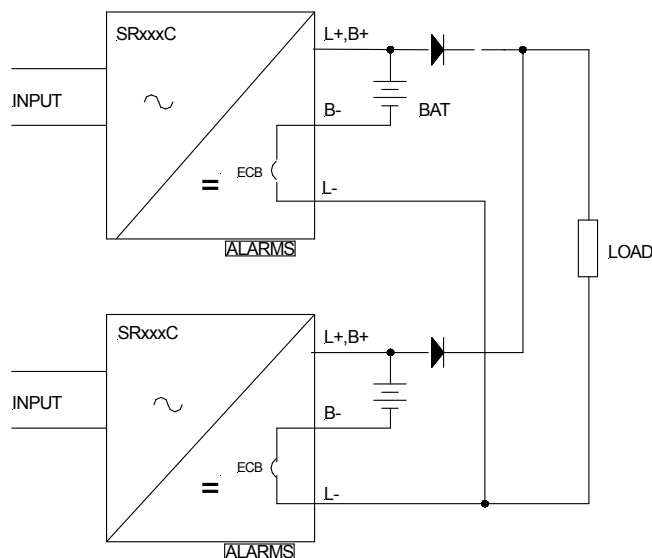

N+1 redundancy for charger and batteries

Alarms Available

Power OK	YES
Battery Missing	YES
Battery Low	YES
Battery Condition Test Fail*1	YES

*1 interlock circuit required for automated BCT

#4 No-Break™ DC Connection for high peak loads

This is a basic connection which is used when there is a connected load with a peak current greater than 1.5 times the rated current of the charger. Standing loads are connected normally and an optional external low voltage disconnect may be used for the peak load.

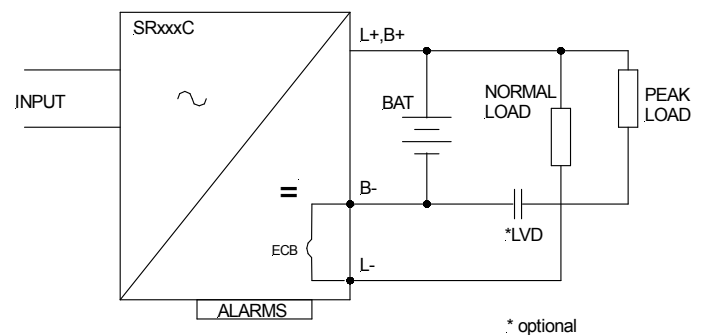

Single battery DC backup system for peak loads

Alarms Available

Power OK	YES
Battery Missing	YES
Battery Low	YES
Battery Condition Test Fail	YES



Global Solutions Personal Focus

TERMS OF WARRANTY

Innovative Energies Ltd warrants its power supplies for 24 months (two years) from date of shipment against material and workmanship defects.

Innovative Energies' liability under this warranty is limited to the replacement or repair of the defective product as long as the product has not been damaged through misapplication, negligence, or unauthorized modification or repair.

Thank you for purchasing from Innovative Energies.

We trust your power supply will exceed your expectations and perform for years to follow.

Sincerely,
The Innovative Energies team.

Innovative Energies Limited

Phone: +64 9 835 0700
Freephone: 0800 654 668 (New Zealand)
1800 148 494 (Australia)
Fax: +64 9 837 3446
Email: info@innovative.co.nz
Online: www.innovative.co.nz
In Person: 1 Heremai Street, Henderson, Auckland, New Zealand
By Post: PO Box 19-501, Auckland 1746, New Zealand