

## **User Manual**

### **SR750L**

#### ***AC/DC POWER SUPPLY & FLOAT CHARGER with alarms & RS485 comms.***



ISO9001  
Certified

## **Safety**

The user is responsible for ensuring that input and output wiring segregation complies with local standards and that in the use of the equipment, access is confined to operators and service personnel. A low resistance earth connection is essential to ensure safety and additionally, satisfactory EMI suppression (see below).

**HAZARDOUS VOLTAGES EXIST WITHIN A POWER SUPPLY ENCLOSURE AND ANY REPAIRS MUST BE CARRIED OUT BY A QUALIFIED SERVICEPERSON.**

## **Electrical Strength Tests**

Components within the power supply responsible for providing the safety barrier between input and output are constructed to provide electrical isolation as required by the relevant standard. However EMI filtering components could be damaged as result of excessively long high voltage tests between input, output and ground. Please contact our technicians for advice regarding electric strength tests.

## **Earth Leakage**

The EMI suppression circuits causes earth leakage currents which may be to the maximum allowable of 3.5mA.

## **Ventilation**

High operating temperature is a major cause of power supply failures, for example it has been well documented that a 10°C rise in the operating temperature of a component will halve its expected life. Therefore always ensure that there is adequate ventilation for the equipment. Batteries and cooling fans also suffer shortened lifetimes if subjected to high ambient temperatures - both should be included in a routine maintenance schedule to check for signs of reduced efficiency.

## **Water / Dust**

Every effort must be made in the installation to minimise the risk of ingress of water or dust. Water will almost always cause instant failure. The effects of dust are slower in causing failure of electronic equipment but all electrical equipment should be cleaned free of any dust accumulation at regular intervals. This is particularly important where internal fans are fitted.

## **Electromagnetic Interference (EMI)**

Switching power supplies and converters inherently generate electrical noise. All wiring should be as short as practicable and segregated from all equipment wiring which is sensitive to EMI. Residual noise can be reduced by looping DC wiring through ferrite cable sleeves. These are most effective as close to the power supply as possible and as many turns of the wire taken through the core (+ and - in the same direction) as the core will accommodate.

## **Fuse ratings**

Check that the wiring and fuses or MCBs match the rating of the PSU or converter. Adequate fuse protection of battery circuits is very important owing to the large potential currents available from batteries.

## **Connection polarity**

It is critical to check the polarity carefully when connecting DC power supplies and chargers to equipment. Boost chargers and some float chargers usual have reverse polarity protection (RPP), which can be electronic (non-destructive) or by an internal fuse which needs to be replaced if a battery is connected in reverse.

## **Glossary of terms used in our user manuals**

**PSU** = power supply unit

**BCT** = battery condition test

**ECB** = electronic circuit breaker

**ELVD** = electronic low voltage disconnect

**RPP** = reverse polarity protection

**EMI** = electromagnetic interference

**SNMP** = Simple Network Management Protocol

**LAN** = local area network

**DOD** = depth of discharge

## 1. INTRODUCTION

The **SR750L** range is designed for use as a very accurate AC to DC power supply, or float charger for lead acid batteries. Note that for float charging the output voltage must be set to approximately 15% above the nominal battery voltage.

## 2. CONNECTIONS

If used as a float charger always connect the positive output of the power supply to the positive terminal of the battery. The charger may be permanently connected to float charge lead acid batteries but it is essential to periodically check the electrolyte level of flooded cells as there is always some evaporation. Where screw/plug in terminals are fitted (eg. SR500A24FXL), and there are two terminals provided for each polarity, both terminals must be used. This is to ensure that the current rating of the terminal block is not exceeded.

### CONNECTION LAYOUT

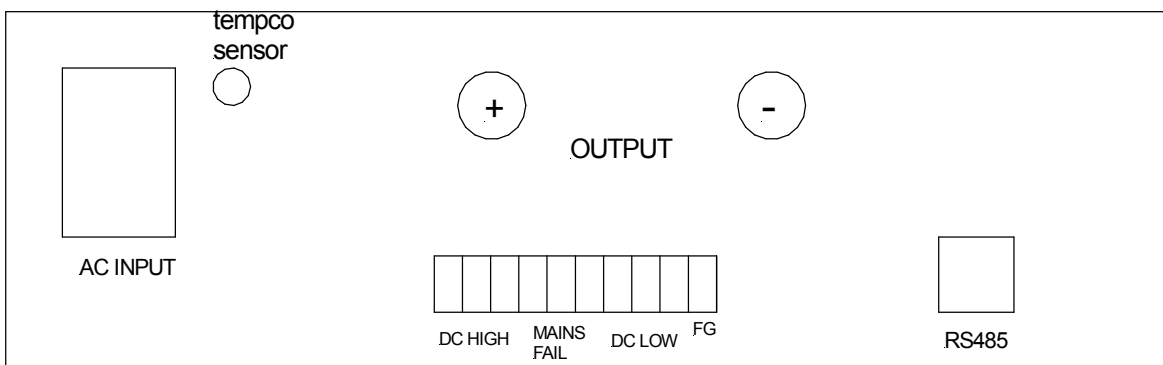

### ALARM TERMINAL LAYOUT

DC HIGH			MAINS FAIL			DC OK			FG
COM	NC	NO	COM	NC	NO	COM	NC	NO	

Relay contacts shown in **de-energised** state (ie when there is a fault condition).  
Alarm relays are **energised** when power supply is operating normally.  
FG terminal is connected to the metal case.

## 3. LED INDICATION CODES

**DC OK** LED indicates DC output is present, either from PSU or battery (if connected)

*Slow flash:* **DC LOW**

*Fast flash:* **DC HIGH**

**POWER OK** LED indicates input power on (unless there is a short circuit on the output)

## 4. STANDBY FUNCTION

Pushing the **STANDBY** button turns the output of the power supply off. If there is a battery connected, the **DC OK** LED remains on even though the power supply is turned off.

## 5. INPUT CONNECTIONS FOR DC INPUT MODELS

BROWN :                      POSITIVE +  
BLUE:                         NEGATIVE -  
GREEN/YELLOW:             EARTH



Optional internal V/I meter shown

*Ideal as a Standby Float Charger for lead acid batteries*

◆ 24 Month Warranty

**SPECIFICATIONS** All specifications are typical at nominal input, full load and at 20°C unless otherwise stated.

**ELECTRICAL**

<b>Input - standard - option</b>	230VAC (180 - 264), 45-65Hz 110VAC (88 - 132), 45-65Hz
<b>Fusing</b>	Internal input fuse
<b>Overload protection</b>	Constant current limit under overload and short circuit conditions (except DC input versions which have primary current limit)
<b>Isolation</b>	1KV DC input - output / earth
<b>Over voltage protection</b>	130% of nominal output voltage
<b>Efficiency</b>	≥ 85%
<b>Inrush current</b>	Soft start circuit
<b>Output power</b>	750W
<b>Output voltage</b>	Refer to model table
<b>Line regulation</b>	<0.2% over AC input range
<b>Load regulation</b>	<0.4% open circuit to 100% load
<b>Noise</b>	<1%
<b>Drift</b>	0.03% / °C
<b>Hold-up time</b>	15 - 20 ms without battery
<b>Thermal protection</b>	Yes, self resetting
<b>Parallel operation</b>	Yes
- higher power	Addition of external output diodes optional
- N+1 redundancy	Use with external output diodes
<b>Alarms</b>	<ul style="list-style-type: none"> <li>• <b>Mains fail</b></li> <li>• <b>DC low</b> (Battery low or PSU low) <ul style="list-style-type: none"> <li>- Charger: set at 1.83V/cell</li> <li>- PSU: set at 83% V out</li> </ul> </li> <li>• <b>DC high</b></li> </ul>
<b>Alarm contacts</b>	C - NO - NC changeover rated 1A /50V DC, 32VAC

**PHYSICAL**

<b>AC input connector</b>	IEC320 inlet socket
<b>DC connections</b>	M8 brass stud or plug in/screw terminal block
<b>Alarm connections</b>	Plug-in screw terminal block
<b>Enclosure</b>	Powder coated steel
<b>Dimensions</b>	225W x 70H x 304D mm (excl. terminals)
<b>Weight</b>	4.3 Kg
<b>Indication LEDs</b>	<b>Standard:</b> Power OK, Standby <b>With alarms:</b> DC OK, Power OK, Standby
<b>Standby switch</b>	Turns off DC output of PSU

**ENVIRONMENTAL**

<b>Operating temperature</b>	0 to + 50 °C ambient at full load De-rate linearly >50 °C to no load @ 70 °C
<b>Storage temperature</b>	-10 to 85 °C ambient
<b>Humidity</b>	0 - 95% relative humidity non-condensing
<b>Cooling</b>	Fan cooled

**STANDARDS**

<b>EMI</b>	To CISPR 22 / EN55022 class A
<b>Safety</b>	To IEC950 / EN60950 / AS/NZS3260

**ACCESSORIES SUPPLIED**

Mounting feet together with screws  
AC power cord 1.5m with IEC320 socket and NZ/Aust plug  
Mating screw-terminal plug for alarm outputs  
Crimp lugs for stud terminal versions  
DC screw terminal plug-in connector for 'X' version

# 750 Watt AC/DC Stand Alone Power Supply/Float Charger

# SR750L

## STANDARD MODEL TABLE

MODELS	Power Supply		Battery Charger		Adjustable range (V)
	Output Volts (factory default)	Output Current (A) (continuous)	Output Volts* (Charging)	Output Current (A) (Charging)	
SR750L12	13.8	54 (54 @ 11-14V)	13.8	54	11-14
SR750L24	24	31.2	27.6	27	22- 29
SR750L30	30	25	34.5	21.7	28-36
SR750L36	36	20.8	41.4	18	34-43
SR750L48	48	15.6	55.2	13.6	45-57
SR750L91	96	7.8	110	6.8	90-115
SR750L92	108	6.9	124	6.0	100-130
SR750L93	120	6.2	138	5.4	110-145

\* Please specify on ordering that unit is to be used for float charging (except for 12V model which is set at 13.8V by default).



Rear view

## OPTIONS

<b>Temperature compensation for charging</b>	Temperature sensor on 1.7m lead with adhesive pad: -4mV / °C / cell ±10% Order Code: <b>+TEMPCO</b>
<b>DC Input</b>	110VDC (99-150) 220VDC (180-270) Please note that an external fuse or MCB must be fitted on the output for short circuit protection.
<b>Earth fault alarm (external to PSU))</b>	Detects leakage to earth of DC output and provides relay output Code: <b>+ALARM/EFDM (20-60V)</b> <b>+ALARM/EFDH (61-150V)</b>
<b>Communications port</b>	Choice of RS485, RS232, ethernet (SNMP or ASCII)

## OPTIONS (continued)

<b>Internal V/I meter</b>	Add code: <b>+INT-METER</b>
<b>Mounting options:</b>	
<b>19" rack mount</b>	2U sub rack available, Code: <b>SR-RM2U</b> Optional V/I meter, Code: <b>SR-METER</b>
<b>Wall mount enclosure</b>	PSU may be fitted into enclosure with MCBs and terminals. Code: <b>SEC-SR</b>

## MODEL IDENTIFICATION CODES

# SR750L 12 T F S L-485

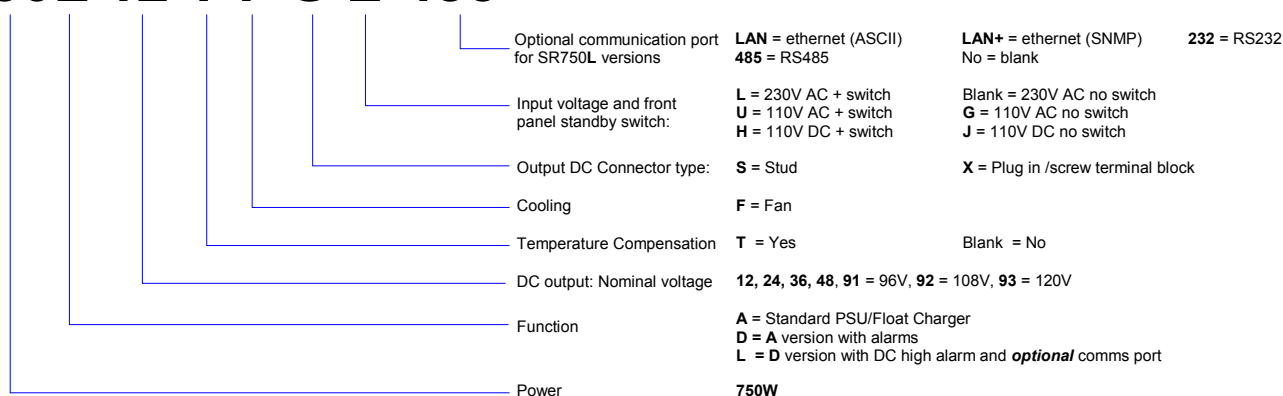

**CONNECTION FOR PARALLEL REDUNDANCY**

Two or more **SR750L** power supplies may be connected in parallel for increased power or parallel redundancy. Figure 1 below shows two **SR750L** units connected with external diodes. It is essential that the wiring from each unit to the load is kept identical for equal power sharing particularly when diodes are not used.

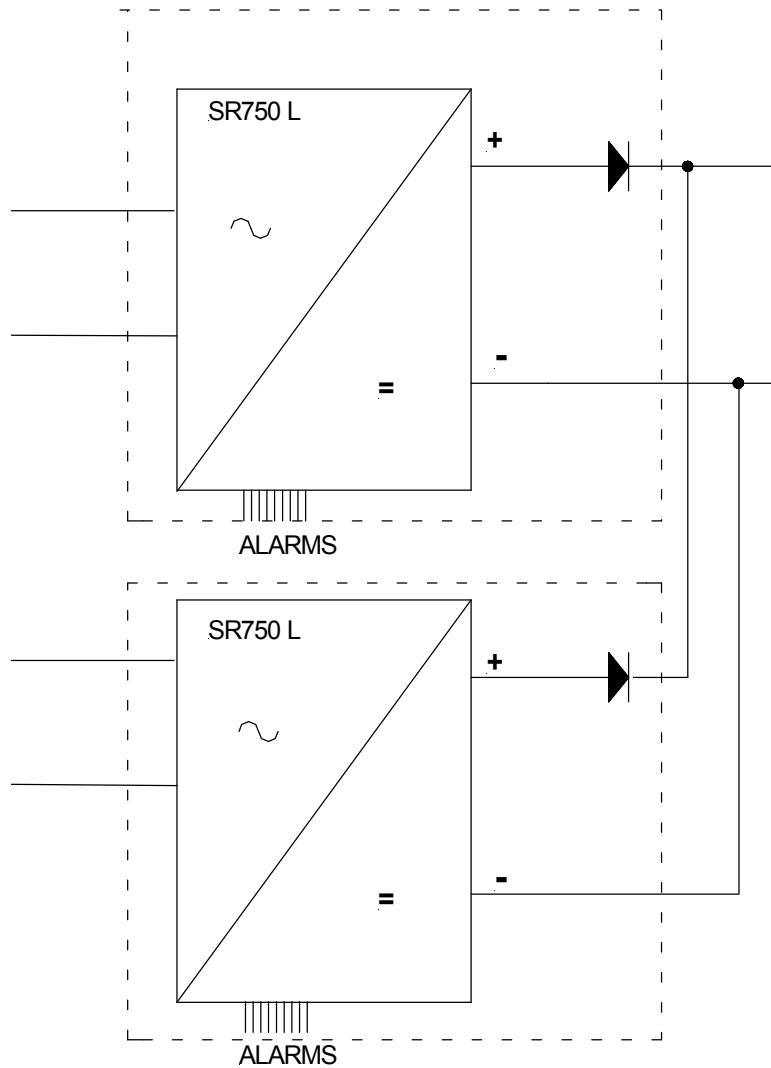

# *Notes*

## TERMS OF WARRANTY

Innovative Energies Ltd warrants its power supplies for 24 months (two years) from date of shipment against material and workmanship defects.

Innovative Energies' liability under this warranty is limited to the replacement or repair of the defective product as long as the product has not been damaged through misapplication, negligence, or unauthorized modification or repair.

Thank you for purchasing from Innovative Energies.

We trust your power supply will exceed your expectations and perform for years to follow.

Sincerely,  
The Innovative Energies team.

## Innovative Energies Limited

Phone: +64 9 835 0700  
Freephone: 0800 654 668 (New Zealand)  
1800 148 494 (Australia)

Fax: +64 9 837 3446

Email: [info@innovative.co.nz](mailto:info@innovative.co.nz)

Online: [www.innovative.co.nz](http://www.innovative.co.nz) or [www.innovative-energies.com](http://www.innovative-energies.com)

In Person: 1 Heremai Street, Henderson, Auckland, New Zealand

By Post: PO Box 19-501, Auckland 1746, New Zealand