

User Manual

SR750i....LAN+

**No-Break™ DC UPS with SNMP communications port
750W**



(optional V/I meter shown)



Please refer to separate user manual for full SNMP instructions

Safety

The user is responsible for ensuring that input and output wiring segregation complies with local standards and that in the use of the equipment, access is confined to operators and service personnel. A low resistance earth connection is essential to ensure safety and additionally, satisfactory EMI suppression (see below).

HAZARDOUS VOLTAGES EXIST WITHIN A POWER SUPPLY ENCLOSURE AND ANY REPAIRS MUST BE CARRIED OUT BY A QUALIFIED SERVICEPERSON.

Electrical Strength Tests

Components within the power supply responsible for providing the safety barrier between input and output are constructed to provide electrical isolation as required by the relevant standard. However EMI filtering components could be damaged as result of excessively long high voltage tests between input, output and ground. Please contact our technicians for advice regarding electric strength tests.

Earth Leakage

The EMI suppression circuits causes earth leakage currents which may be to the maximum allowable of 3.5mA.

Ventilation

High operating temperature is a major cause of power supply failures, for example it has been well documented that a 10°C rise in the operating temperature of a component will halve its expected life. Therefore always ensure that there is adequate ventilation for the equipment. Batteries and cooling fans also suffer shortened lifetimes if subjected to high ambient temperatures - both should be included in a routine maintenance schedule to check for signs of reduced efficiency.

Water / Dust

Every effort must be made in the installation to minimise the risk of ingress of water or dust. Water will almost always cause instant failure. The effects of dust are slower in causing failure of electronic equipment but all electrical equipment should be cleaned free of any dust accumulation at regular intervals. This is particularly important where internal fans are fitted.

Electromagnetic Interference (EMI)

Switching power supplies and converters inherently generate electrical noise. All wiring should be as short as practicable and segregated from all equipment wiring which is sensitive to EMI. Residual noise can be reduced by looping DC wiring through ferrite cable sleeves. These are most effective as close to the power supply as possible and as many turns of the wire taken through the core (+ and - in the same direction) as the core will accommodate.

Fuse ratings

Check that the wiring and fuses or MCBs match the rating of the PSU or converter. Adequate fuse protection of battery circuits is very important owing to the large potential currents available from batteries. Our **No-Break DC** series has an internal ECB for protection of the battery circuit but for all other charging situations should have an external fuse or circuit breaker fitted in the battery circuit.

Connection polarity

It is critical to check the polarity carefully when connecting batteries and equipment to DC power supplies and chargers. Boost chargers (and some float chargers) made by Innovative Energies have reverse polarity protection, which can be by an electronic switch (non-destructive) or an internal fuse which needs to be replaced if a battery is connected in reverse.

Glossary of terms used in our user manuals

PSU = power supply unit

BCT = battery condition test

ECB = electronic circuit breaker

ELVD = electronic low voltage disconnect

RPP = reverse polarity protection

EMI = electromagnetic interference

SNMP = Simple Network Management Protocol

LAN = local area network

INTRODUCTION

The **No-Break™ DC** power supply is designed to provide DC power to lead acid batteries for critical back up applications. In addition to the normal features of the standard **SR750C..** model, the **SR750i....-LAN+** has an ethernet communication interface using SNMP protocol to enable user monitoring of the power supply and battery parameters and control of the battery condition test function.

No-Break™ SYSTEM BLOCK DIAGRAM

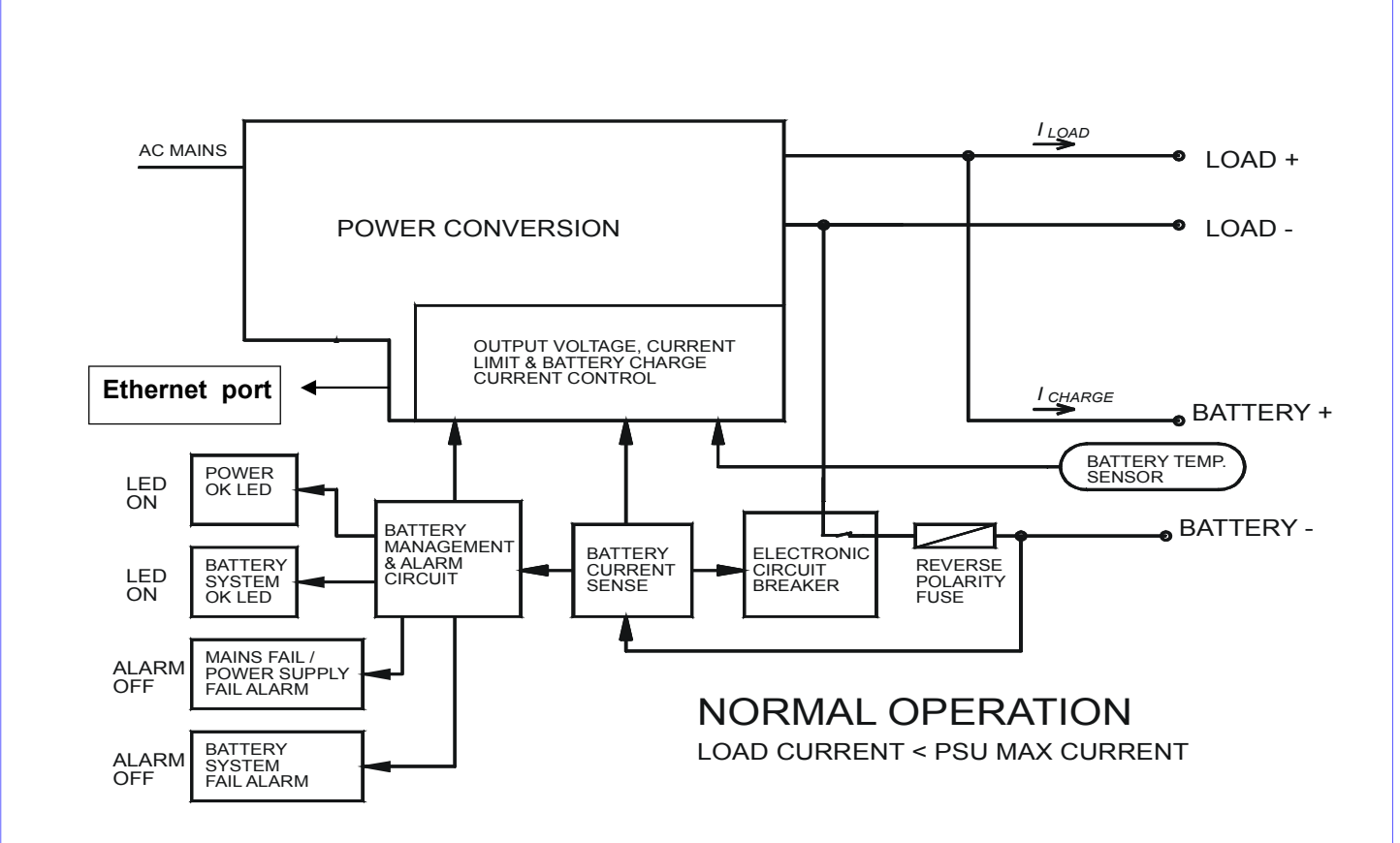

OPERATION OF ELECTRONIC CIRCUIT BREAKER (ECB) FOR PROTECTION OF BATTERY CIRCUIT

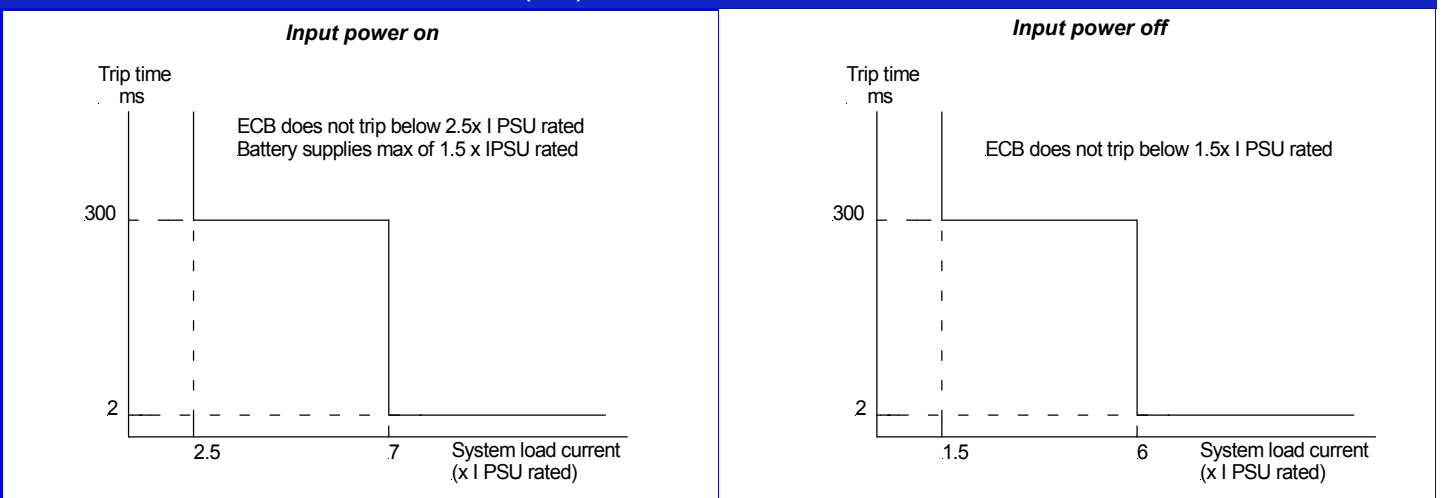

The ECB is activated under the following conditions:

1. battery voltage drops below the V_{disco} (1.66V/cell)
2. battery current overload (refer to graphs above)

The ECB will latch open only when there is no input power present. It will reset when input power is restored or can be manually reset by briefly shorting the **BAT-** and **LOAD-** terminals together when there is no input power.

L+, B+ are linked internally and labelled **COM** on stud terminal output versions

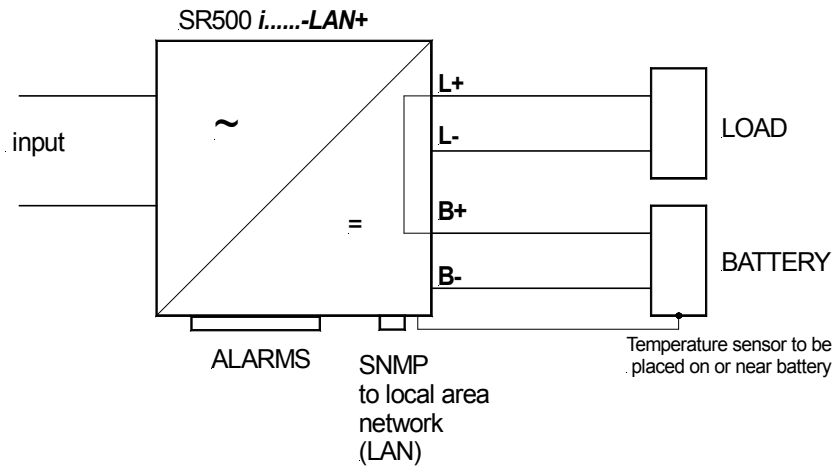

CONNECTION & INITIAL TESTING

- 1 Check input and output voltages of system, ensure that they match the equipment. All loads should be isolated.
- 2 Check polarity of all wiring. Place temperature sensor probe near or on batteries.
- 3 Plug in input power. "POWER OK" LED will light up. DC output voltage should appear at both load and battery outputs.
- 4 Turn off input power.
- 5 Connect battery.
- 6 Check that ECB (internal electronic circuit breaker) closes by shorting together the **BATTERY -ve** and **LOAD -ve** terminals briefly. Both LEDs will light up. If this does not happen, there is a fault in the wiring or the internal battery protection fuse is ruptured (see Note 2 below). The battery voltage will then appear at the load terminals and the "BAT LOW" alarm relay energises. The "POWER OK" LED stays on for about 30 seconds.
- 7 Connect load wiring to **LOAD+** and **LOAD-** terminals.
- 8 The system is now ready for operation.
- 9 Please refer to separate user manual for setting up the SNMP web interface.

NOTES

- 1 **Maximum current available** (using normal No-Break DC connection, refer to peak load connection #4 on page 10 if higher currents required)
 - with input power present: 2.5 x rated PSU current
 - with no input power: 1.5 x rated PSU current
- 2 **Reverse polarity protection**
 If the battery is connected in reverse, the internal battery protection fuse may be ruptured and the unit should be returned to the manufacturer for repair. If the fuse is good, the voltage measured as at step 3 above should be exactly the same on both the load and battery outputs.
- 3 **Battery Condition Test (BCT)**
 BCT function is disabled on start up and is controlled via the SNMP interface.
- 4 **BCT fail reset**
 If the system fails a BCT the **BAT LOW** alarm latches (de-energized state) until
either: both the mains power input and the battery are disconnected briefly
or: the system passes the next BCT.

DIMENSIONS

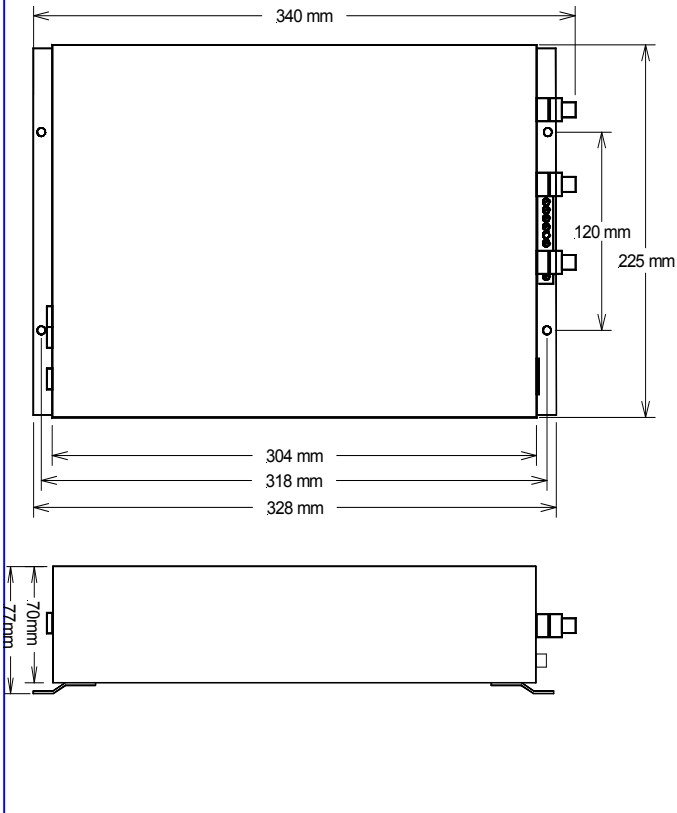

CONNECTION LAYOUT

Stud terminals

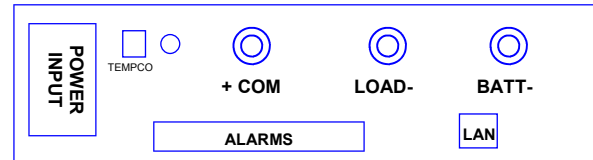

NOTE: LOAD+ / BATT+ terminals are linked internally and are connected to the +COM terminal

FRONT PANEL LEDS (WITH BUILT IN SWITCHES)

For full list of LED flash codes please refer to page 7.

BATTERY SYSTEM OK: **LED on:** Battery present and above V batl.

POWER OK: **LED on:** Input power present

STANDBY: **LED on:** Charger in standby mode (no output from charger)

Warning: Do not put unit into standby mode during normal operation as "BATLOW" alarm and low voltage disconnect are both disabled.

ALARM RELAYS

AUX: Relay is energized when the battery condition test is in progress

MAINS FAIL: Alarm indicates loss of input power after 30 sec delay.

BAT LOW: Relay is de-energized when either:

































1. battery voltage = 1.8V/cell (for 2V cells) - operates only when no input power present **or**
2. battery missing or fault in battery circuit wiring (alarm does not activate for up to battery detection interval time).





SPECIFICATIONS (at 20 degrees C)

| Parameter | Nominal Voltage | | | | | Default Value |
|--|-----------------|------|------|------|------|------------------|
| | 12V | 24V | 30V | 36V | 48V | |
| V out = Output voltage * ¹ | 13.8 | 27.6 | 34.5 | 41.4 | 55.2 | 2.3V/cell |
| V pres = Voltage threshold for battery detection & battery condition test (BCT). If voltage drops to this level during BCT then the test is aborted and BATT SYS OK relay de-energises | 12.2 | 24.4 | 30.5 | 36.6 | 48.8 | 2.03V/cell |
| V shudt = Output voltage of PSU during battery detection & BCT | 11.5 | 23 | 28.8 | 34.5 | 46 | 1.92V/cell |
| V batl = Battery low alarm voltage during mains fail. (BATT SYS OK alarm relay de-energizes) | 11 | 22 | 27.6 | 33 | 44 | 1.84V/cell |
| V disco = Battery disconnect voltage during mains fail | 10 | 20 | 25 | 30 | 40 | 1.66V/cell |
| Bccl = Maximum charge current as % of rated PSU rated current | | | | | | 100% |
| Comms = communications mode of PSU: F = continuous data stream of status M = responds only to request made by a controller | | | | | | M |
| BatDetect = Battery detection interval time, active only when no battery charge current is detected (the unit may not detect a missing battery for up to this time) | | | | | | 60 min |
| BCT = length of battery condition test | | | | | | 20 min |
| Ret = retest option: N = after a failed BCT further scheduled BCTs are inhibited Y = after a failed BCT further scheduled BCTs will be allowed | | | | | | Y |
| CC = Length of charge cycle in minutes/hours/days. ie. time between battery condition tests | | | | | | 40m/23h/ 027d |

*1 Output voltage is set by an internal potentiometer.

LED INDICATION CODES

| Battery System OK LED | Power OK LED | Stand-by LED | Battery System OK Alarm | Power OK Alarm | Condition |
|---|---|---|-------------------------|----------------|--|
|  |  |  | Normal | Normal | System Normal: Input power on, battery circuit is OK |
|  |  |  | Normal | Normal | Battery detection test in progress |
|  |  |  | Alarm | Normal | Input power on, battery system fault: 1. Internal battery fuse has opened or 2. Battery circuit wiring open circuit, battery missing, ECB has tripped |
|  |  |  | Normal | Alarm | Input power off, battery system is OK (battery volts > Vbatl) |
|  |  |  | Alarm | Alarm | Input power off and battery has discharged to $\leq V_{batl}$ |
|  |  |  | Alarm | Alarm | Input power off, ELVD has activated and disconnected battery from load. |
|  |  |  | Normal | Normal | BCT is in progress: LEDs flash slowly |
|  |  |  | Alarm | Normal | Input power on, failed previous BCT - battery voltage < Vpres during the BCT |
|  |  |  | Normal | Normal | PSU in standby, input power on, battery system OK |
|  |  |  | Alarm | Alarm | PSU in standby, input power present, battery missing. |
|  |  |  | Alarm | Normal | PSU in standby and system has failed previous BCT |

LEGEND :  =on  =fast flash  =slow flash  =off



Optional internal V/I meter shown

- Remote monitoring of DC system via internet connection
- BCT controlled via web page or SNMP MIB browser
- Includes all the features of our standard **No-Break DC UPS** systems
- Separate outputs for load and battery
- Battery detection - regular battery presence and battery circuit integrity checks
- Deep discharge protection for battery
- ECB for overload protection of battery circuit
- Fused reverse battery polarity protection
- Automatic temperature compensated output volts
- **No-Break** switching between PSU & battery
- LED flash codes for precise state indication
- Two alarm relay outputs standard + BCT relay

◆ 24 Month Warranty

SPECIFICATIONS All specifications are typical at nominal input, full load and at 20°C unless otherwise stated.

| ELECTRICAL | |
|-------------------------------------|--|
| AC Input | 230V AC: 180V - 264V (standard) 110V AC: 88V - 132V (on request) |
| Frequency | 45- 65 Hz |
| Fusing / Protection | Input fuse Output fuse & ECB for battery |
| Isolation | 1KV DC input - output / earth |
| Efficiency | ≥ 85% |
| Inrush current | Soft start circuit |
| Output Power | 750W |
| Output Voltages | 13.8, 27.6, 34.5, 41.4, 55.2V |
| Voltage adj. range | 85 - 105% of Vout |
| Temp. Compensation | Temperature sensor on 1.7m lead with adhesive pad: -4mV / °C / cell ±10% |
| Current Limits | PSU: 100% rated current Battery: 25-100% PSU current |
| Line Regulation | <0.2% over AC input range |
| Load Regulation | <0.4% open circuit to 100% load |
| Noise | <1% |
| Drift | 0.03% / °C |
| Hold-up time | 15 - 20 ms (nom. - max. Vin) without battery |
| Thermal Protection | Yes, self resetting |
| OVP | Over-voltage protection on output at ~ 130% of nominal output voltage |
| Battery Condition Test (BCT) | Settings to be specified at time of order. Control of BCT is implemented using the SNMP software. BCT relay provided to control an external test load. Please do not hesitate to ask our sales staff for assistance with this feature. |

| No-Break™ FUNCTIONS AND ALARMS* | |
|---------------------------------|---|
| Battery Charge Limit | See Model Table for default settings - may be increased to PSU rated current |
| Reverse Polarity | Battery reverse connection will open internal fuse (and produce alarm) |
| Battery Monitoring | Detects for presence of battery on start up, then every 60 minutes when charge current < 200mA |
| Battery Protection | Electronic Circuit Breaker (ECB) operates under the following conditions: |
| - low battery volts | • battery voltage drops to 1.67V/cell - auto reset |
| - overload | • < 300ms for load > 6 x rated PSU current, allows ~1.5x rated PSU current from battery without acting, |
| - short circuit | • < 2ms, backed up by fuse |
| Indication LEDs | Green: Battery System OK, Power OK Red: Standby |
| Alarms | • Power OK (Mains/PSU fail, standby mode) • Battery System OK - alarms when battery voltage low (on mains fail), battery missing, battery circuit wiring faulty, BCT fail (if enabled) |
| Alarm Relay contacts | C - NO - NC full changeover rated 1A /50V DC, 32VAC |
| Standby Mode | Turns off DC output of PSU & allows load to run off battery |

| ENVIRONMENTAL | |
|------------------------------|--|
| Operating temperature | 0 - 50 °C ambient at full load De-rate linearly >50 °C to no load @ 70 °C |
| Storage temperature | -10 to 85 °C ambient |
| Humidity | 0 - 95% relative humidity non-condensing |
| Cooling | Fan cooled |

| STANDARDS | |
|---------------|----------------------------------|
| EMI | to CISPR 22 / EN55022 class A |
| Safety | to IEC950 / EN60950 / AS/NZS3260 |

750 Watt No-Break™ DC charger for lead acid batteries

SR750i

STANDARD MODEL TABLE

| MODELS | DC Output | | | | |
|----------|------------|---------------|---------------------|------------------|-----------------------------|
| | Output (V) | PSU Rated (A) | Charge Limit (A) *1 | Recomm. Load (A) | Peak load on power fail (A) |
| SR750i12 | 13.8 | 54 | 54 | 42 | 81 |
| SR750i24 | 27.6 | 27 | 27 | 19 | 40 |
| SR750i30 | 34.5 | 21 | 21 | 14 | 31 |
| SR750i36 | 41.4 | 18 | 18 | 12 | 27 |
| SR750i48 | 55.2 | 13.5 | 13.5 | 8.5 | 20 |

*1 charge current limit may be varied at time of order



No-Break™ DC

SCHEMATIC BLOCK DIAGRAM

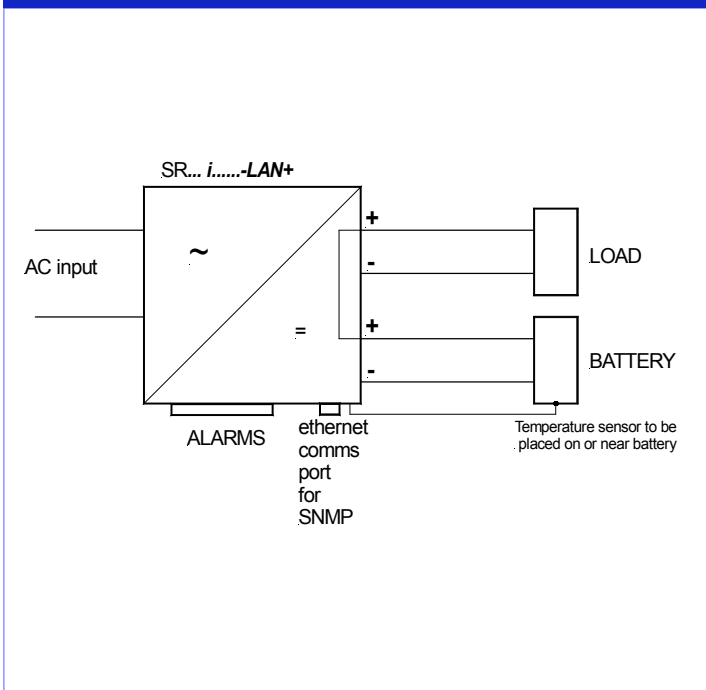

PHYSICAL

| | |
|------------------------------|--|
| AC Input connector | IEC320 inlet socket |
| DC Output Connections | M8 brass stud or plug-in/ screw terminal block (20A/ terminal) |
| Alarm Connections | Plug in/ screw terminal block |
| Enclosure | Powder coated steel |
| Weight | 4.3kg |
| Dimensions | 225W x 304D x 70H mm (excluding mounting feet and terminals) |

OPTIONS

| | |
|-----------------------------------|---|
| 19" Rack Mount | 2U sub rack option: add SR-RM2U Optional V/I meter for subrack: SR-METER |
| Wall Mount Enclosure | PSU may be fitted into enclosure with MCBs and terminals. Code: SEC-SR |
| Parallel redundancy | Use external output diode, eg +P50 . Please refer to separate application notes. |
| Internal Digital V/I Meter | Add code +INT-METER |

ACCESSORIES SUPPLIED

- Mounting feet together with screws
- AC power cord 1.5m with IEC320 socket & AUS/NZ plug
- Mating screw terminal plug for DC connector for 'X' version
- Mating screw terminal plug for alarm outputs
- Crimp lugs for 'S' version

MODEL IDENTIFICATION CODES

SR750 i 12 T F S L-LAN+

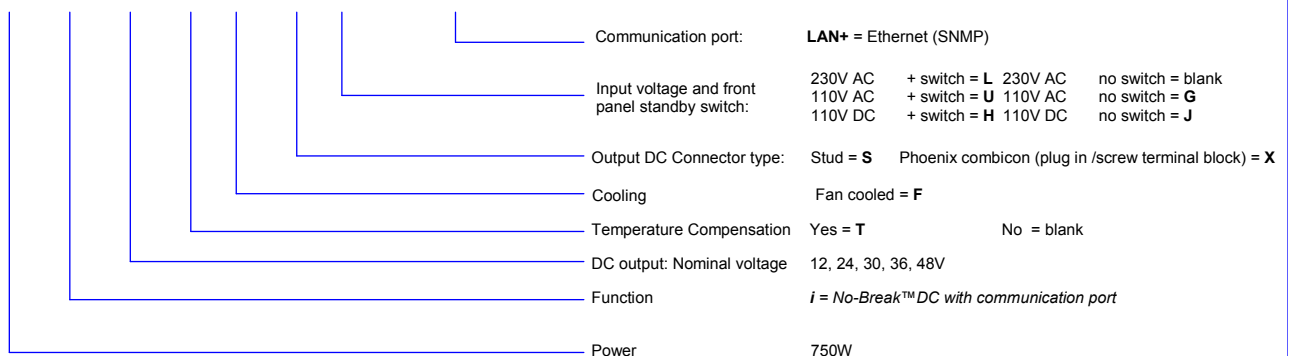

No-Break DC connections for N+1 redundancy & peak loads

#1 N+1 for No-Break™ DC charger and single battery bank

This connection provides for redundancy of the charger and retains most of the No-Break functions.

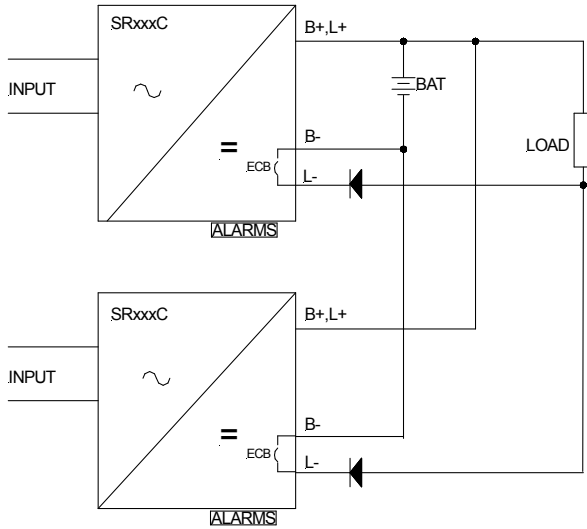

| Alarms available | |
|---|-----|
| Power OK | YES |
| Battery missing | NO |
| Battery low | YES |
| Battery condition test fail* ¹ | YES |

#2 N+1 for No-Break™ DC charger and N+1 for battery bank (use this connection for high peak loads)

All No-Break alarms are available and the low voltage disconnect for the peak load is optionally implemented with an external relay.

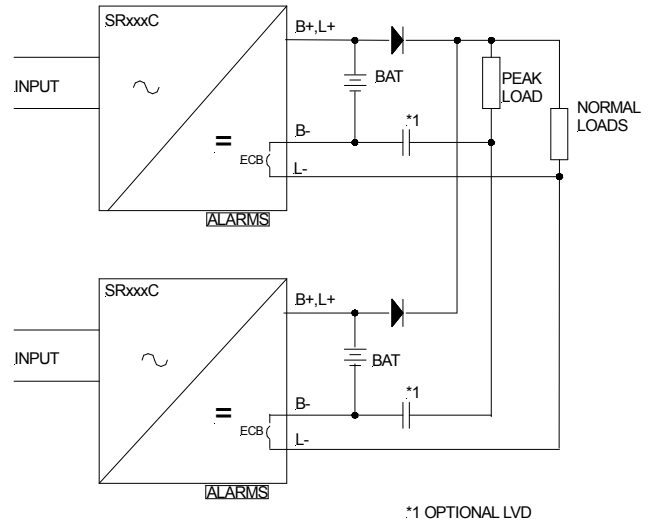

| Alarms available | |
|--|-----|
| Power OK | YES |
| Battery missing | YES |
| Battery low | YES |
| Battery condition test fail * ¹ | YES |

#3 2 x No-Break™ DC chargers and 2 x battery banks

2 x No-Break™ DC chargers connected in parallel with separate battery banks & output diodes. This solution provides an extremely high level of redundancy for very critical applications, with redundancy of the battery in addition to the power supply. The diodes isolate the units from one another in the event of a short circuit appearing at the other output and aid current sharing.

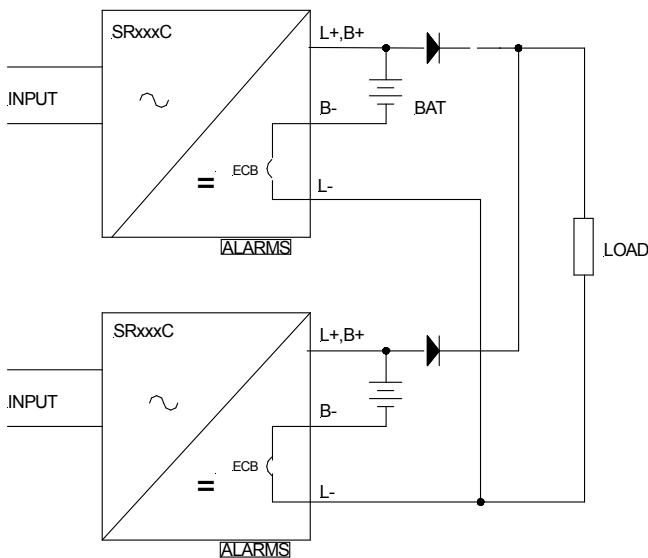

| Alarms Available | |
|---|-----|
| Power OK | YES |
| Battery Missing | YES |
| Battery Low | YES |
| Battery Condition Test Fail* ¹ | YES |

*¹ interlock circuit required for automated BCT

#4 1 x No-Break™ DC Connection for high peak loads

This is a basic connection which is used when there is a connected load with a peak current greater than 1.5 times the rated current of the charger. Standing loads are connected normally and an optional external low voltage disconnect may be used for the peak load.

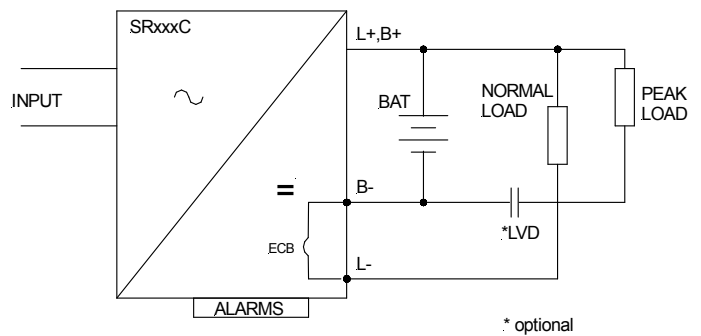

| Alarms Available | |
|-----------------------------|-----|
| Power OK | YES |
| Battery Missing | YES |
| Battery Low | YES |
| Battery Condition Test Fail | YES |

Notes

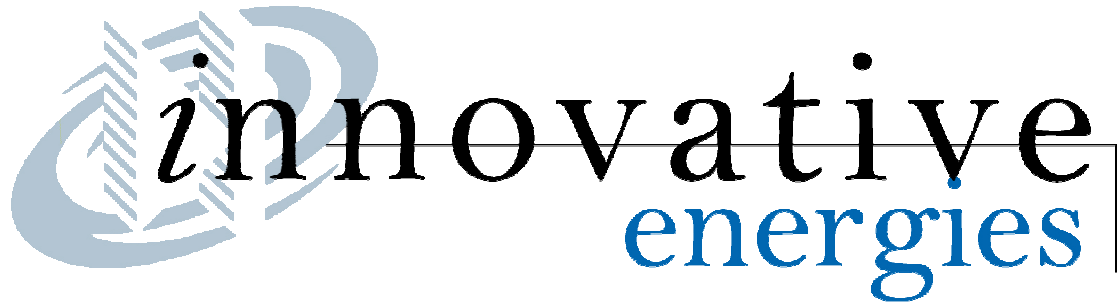
**TERMS OF WARRANTY**

Innovative Energies Ltd warrants its power supplies for 24 months (two years) from date of shipment against material and workmanship defects.

Innovative Energies' liability under this warranty is limited to the replacement or repair of the defective product as long as the product has not been damaged through misapplication, negligence, or unauthorized modification or repair.

Thank you for purchasing from
Innovative Energies.

We trust your power supply will exceed
your expectations and perform for years
to follow.

Sincerely,
The Innovative Energies team.

Innovative Energies Limited

Phone: +64 9 835 0700
Freephone: 0800 654 668 (New Zealand)
1800 148 494 (Australia)
Fax: +64 9 837 3446
Email: info@innovative.co.nz
Online: www.innovative.co.nz or www.innovative-energies.com
In Person: 1 Heremai Street, Henderson, Auckland, New Zealand
By Post: PO Box 19-501, Auckland 1746, New Zealand