

Static Switches

Features

- 115 or 230 VAC input / output
- Any fixed frequency between 40 - 400 Hz
- Power: 0.8 - 10 kVA
- Fast transfer time
- Surge current capability
- Priority selection
- LED display with potential free contacts
- Industrial grade components
- Compact and robust design

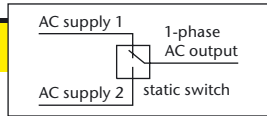

Series SS

Model	Output Power [kVA]	Input / Output [V]
SS 1506	0.8	115
SS 3506	1.6	
SS 3516	3	
SS 3526	5	
SS 3536	10	
SS 1508	0.8	230
SS 3508	1.6	
SS 3518	3.2	
SS 3528	5	
SS 3538	10	

Frequency Designation	
.3	any fixed frequency between 40 - 400 Hz
.4	400 Hz
.5	50 Hz
.6	60 Hz

UPS System with Static Switch

The Static Switch has two inputs for load supply, a priority and a non-priority input, and synchronizes the frequency of one supply to the other. Typically, but not exclusively, supplied by Mains and an Inverter, there are 3 modes of operation:

1. Service mode Mains - mains is selected as the load provider.
2. Service mode Inverter - inverter is selected as the load provider.
3. Automated function with priority selection.

In the automated function the supply of the priority input is connected to the load. If the static switch detects deviation from tolerance through monitoring, it will transfer the load to the non-priority input. When the supply of the priority input has returned to be within parameters of voltage and frequency, the static switch reverses this selection.

For adapting the static switch to different requirements, the priority for mains or inverter operation can be selected externally via an opto-coupler. The static switch can also be inhibited via another opto-coupler for disconnecting the load. LEDs and potential-free relay contacts indicate the mode of operation and / or the status of alarms.

An external manual bypass switch shown in the diagram allows for maintenance of the static switch.

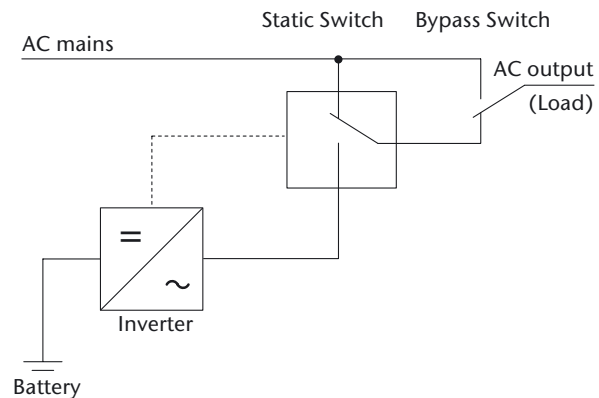

Assistance in table use:

- 1 Select the row for the appropriate voltage and power.
- 2 Add the required frequency designation to the model number.

For example:

- 1 output of 230 VAC @ 1.6 kVA results in SS 3508
- 2 for 50 Hz add .5, i.e. SS 3508.5

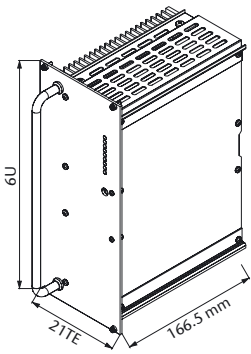

Series SS 15xx
Eurocassette / approx. 3.3 kg
(pluggable module for 19" sub-rack)

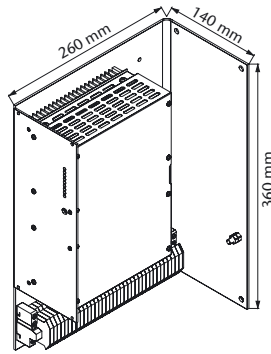

Series SS 15xx
Wall mount / approx. 6.3 kg

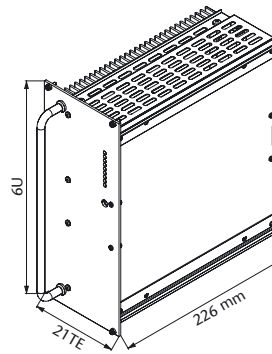

Series SS 35xx
Eurocassette / approx. 5 kg
(pluggable module for 19" sub-rack)

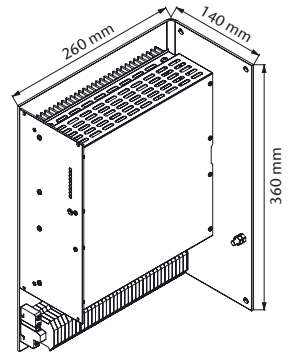

Series SS 35xx
Wall mount / approx. 8 kg

Specifications

Input / Output

Voltage 115 or 230 VAC, single phase
 Frequency any fixed frequency between 40 – 400 Hz
 Power 0.8 – 10 kVA
 Surge current $5 \times I_{nom}$ for 1 s
 Overload protection For models with $I_{nom} \leq 15$ A:
 short circuit protected; unit switches off
 at output current above 15 A
 For models with $I_{nom} > 15$ A:
 an external fuse with slow characteristic
 is required

Transfer time

- mains to inverter (mains priority) or inverter to mains (inverter priority) For models with $I_{nom} \leq 15$ A:
 $\leq \frac{1}{2}$ period, typically $\frac{1}{4}$ period
 (including failure detection time)
 For models with $I_{nom} > 15$ A:
 one period, typically $\frac{1}{2}$ period
 (including failure detection time)

- return to mains (mains priority) or return to inverter (inverter priority) For models with $I_{nom} \leq 15$ A:
 practically no interruption
 For models with $I_{nom} > 15$ A:
 typically $\frac{1}{2}$ period

Transfer trigger $0.8 \times U_{nom} < \text{voltage} < 1.15 \times U_{nom}$
 Priority selection logic low = 0 – 5 V; logic high = 12 – 30 V
 via opto-coupler
 Inhibit (remote on / off) logic low = 0 – 5 V; logic high = 12 – 30 V
 via opto-coupler

Immunity

- ESD acc. to DIN / EN 61000-4-2 level 3
- Fast transients acc. to DIN / EN 61000-4-4 level 3
- Surges acc. to DIN / EN 61000-4-5 level 3

General

Operating temperature -20 to +75 °C
 Load derating 2.5 % / °C from +55 °C
 Storage temperature -40 to +85 °C
 Humidity up to 95 % RH, non-condensing
 Cooling natural convection
 Safety / Construction acc. to DIN / EN 60950-1: 2003
 Protection category IP 20, others or NEMA upon request
 Connector H15 and F48 (details see page 103)
 or terminals

Indication of operation mode

	Green LED	Red LED	potential free contacts *)
Mains operation	■		■
Inverter operation	■		■
Inverter synchronous with mains	■		■
Mains over voltage		■	
Mains under voltage		■	■
Inverter over voltage		■	
Inverter under voltage		■	■
Common alarm		■	■
Service mode		■	

*) $U_{max} = 250$ VAC, $I_{max} = 3$ A

Options (details see page 92 – 93)

Mechanics / environment:

- 19" sub-rack for eurocassette
- Wall mount
- Increased mechanical strength
- Tropical protection
- Extended temperature range to -40 °C