

Yuasa UXH Series VRLA Battery, 10 Years Design Life

Yuasa UXH batteries are constructed to yield even greater capacity than comparable batteries. The UXH uses AGM technology which ensures that there is no 'free acid' in the battery. This allows the battery to be mounted either vertically or horizontally. An additional feature of this product is Yuasa's heavy duty lead calcium-tin alloy, providing the UXH battery the ability to remain in float service for 10 years.

- 10 Year Design Life
- High Energy Density
- Gas Pressure Venting System
- No Equalising Charge Required

General Performance

Battery	UXH100-6	
Application	Floating	
Design Life	10 Years	
Nominal Capacity	100Ah	
Actual Capacity at 25°C	1 hour rate to 1.70 Vpc	58.0Ah
	3 hour rate to 1.70 Vpc	78.0Ah
	10 hour rate to 1.80 Vpc	93.0Ah

Electrolyte

Fully charge density at 20°C	1.300
Density Range	1.290-1.310
Gelled/Absorbed	Absorbed
Mounting Orientation	Vertical/Horizontal

Plates

Positive Plates:	
Number/cell	8
Type	Flat Pasted
Material of grid	Lead-Calcium-Tin Alloy
Thickness	4.0mm
Negative Plates:	
Number/cell	9
Type	Flat Pasted
Material of grid	Lead-Calcium-Tin Alloy
Thickness	2.3mm

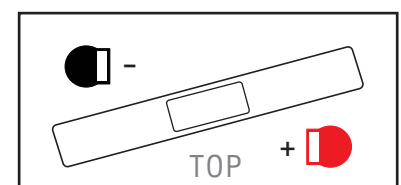

Terminal Type - M6

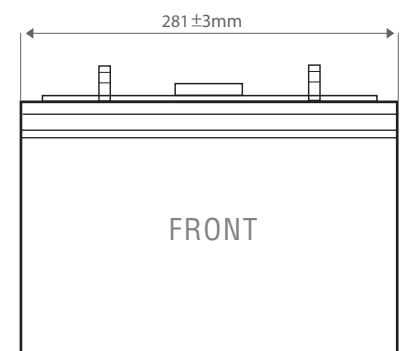
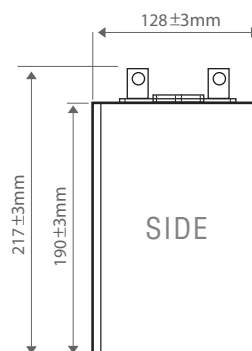
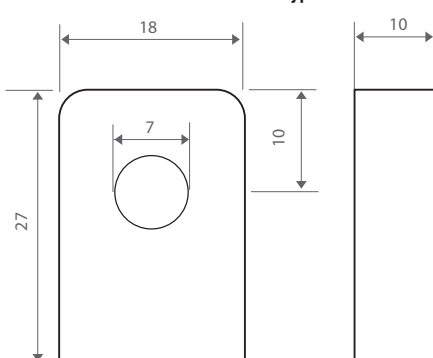

Yuasa UXH Series VRLA Battery, 10 Years Design Life

Physical Properties

Separators	
Type	Glass Mat
Is glass fibre included?	Yes
Thickness	1.5mm
Lid & Container Materials	
Lid Material, Colour	Acrylonitrile Butadiene Styrene ABS/Dark Grey
Container Material, Colour	Acrylonitrile Butadiene Styrene ABS/Dark Grey
Flame Retardant	No
Safety Vent Operational Pressure	20kPA
Flame Arrestor Filter Fitted	Yes
Dimensions:	
Overall Width	281mm ± 3
Depth	128mm ± 3
Height	190mm ± 3
Overall Height	217mm ± 3
Battery Weight (kg) Total (wet)	20kg

Electrical Properties

Self Discharge Rate @ 25°C	<3% per month		
Internal Resistance (mOHMS)	1.8mΩ		
Normal Charge (Amperes)	10A		
Max. Charge (Amperes)	20A		
Max. Sustained Current without damage (discharging 5 sec)	465A		
Volts End of Charge	2.275Vpc		
	20°C	25°C	30°C
Float Voltage (Vpc) pure floating applications	2.290 Vpc	2.275 Vpc	2.260 Vpc
Float Current (mA)	~100mA	~100mA	~100mA
Initial Short circuit current (A)	~3700A		
Efficiency at 10 hour rate (%):			
Ampere-Hour	>90%		
Watt-Hour	>78%		

Torque Setting

Terminal Torque Setting	3.9 - 5.4 N.m.
-------------------------	----------------

Compliant Standard

Battery Standard	JIS C8704-2: 1999
------------------	-------------------

Discharge Characteristics

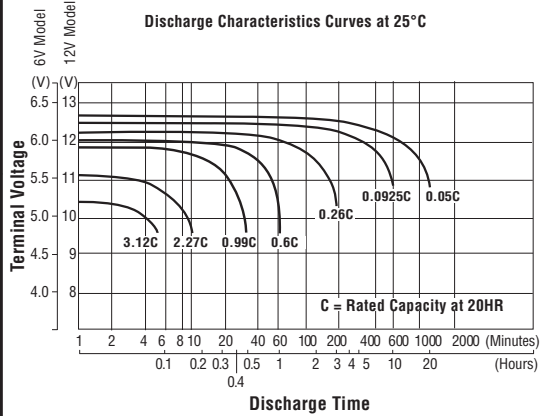

Charging Characteristics

