

## Yuasa UXH Series VRLA Battery, 10 Years Design Life

Yuasa UXH batteries are constructed to yield even greater capacity than comparable batteries. The UXH uses AGM technology which ensures that there is no 'free acid' in the battery. This allows the battery to be mounted either vertically or horizontally. An additional feature of this product is Yuasa's heavy duty lead calcium-tin alloy, providing the UXH battery the ability to remain in float service for 10 years.

- 10 Year Design Life
- High Energy Density
- Gas Pressure Venting System
- No Equalising Charge Required

### General Performance

Battery	UXH125-6FR	
Application	Floating	
Design Life	10 Years	
Nominal Capacity	125Ah	
Actual Capacity at 25°C	1 hour rate to 1.70 Vpc	72.5Ah
	3 hour rate to 1.70 Vpc	97.5Ah
	10 hour rate to 1.80 Vpc	116Ah

### Electrolyte

Fully charge density at 20°C	1.300
Density Range	1.290-1.310
Gelled/Absorbed	Absorbed
Mounting Orientation	Vertical/Horizontal

### Plates

<b>Positive Plates:</b>	
Number/cell	10
Type	Flat Pasted
Material of grid	Lead-Calcium-Tin Alloy
Thickness	4.0mm
<b>Negative Plates:</b>	
Number/cell	11
Type	Flat Pasted
Material of grid	Lead-Calcium-Tin Alloy
Thickness	2.3mm

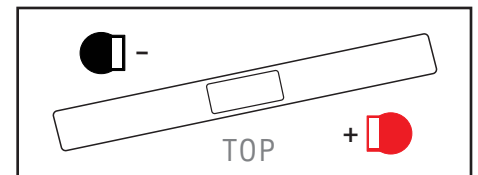

Terminal Type - M6

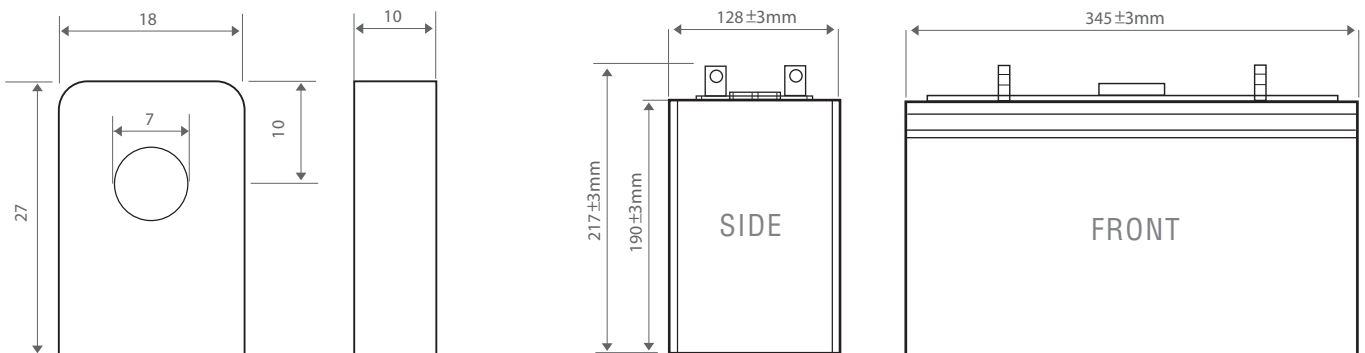

## Yuasa UXH Series VRLA Battery, 10 Years Design Life

### Physical Properties

Separators	
Type	Glass Mat
Is glass fibre included?	Yes
Thickness	1.5mm
Lid & Container Materials	
Lid Material, Colour	Acrylonitrile Butadiene Styrene ABS/Dark Grey
Container Material, Colour	Acrylonitrile Butadiene Styrene ABS/Dark Grey
Flame Retardant	Yes - UL94 - FV-0
Safety Vent Operational Pressure	20kPa
Flame Arrestor Filter Fitted	Yes
Dimensions:	
Overall Width	345mm ± 3
Depth	128mm ± 3
Height	190mm ± 3
Overall Height	217mm ± 3
Battery Weight (kg) Total (wet)	24kg

### Electrical Properties

Self Discharge Rate @ 25°C	<3% per month		
Internal Resistance (mOHMS)	1.5mΩ		
Normal Charge (Amperes)	12.5A		
Max. Charge (Amperes)	25A		
Max. Sustained Current without damage (discharging 5 sec)	580A		
Volts End of Charge	2.275 Vpc		
	<b>20°C</b>	<b>25°C</b>	<b>30°C</b>
Float Voltage (Vpc) pure floating applications	2.290 Vpc	2.275 Vpc	2.260 Vpc
Float Current (mA)	~125mA	~125mA	~125mA
Initial Short circuit current (A)	~4550A		
Efficiency at 10 hour rate (%):			
Ampere-Hour	>90%		
Watt-Hour	>78%		

### Torque Setting

Terminal Torque Setting	3.9 - 5.4 N.m.
-------------------------	----------------

### Compliant Standard

Battery Standard	JIS C8704-2: 1999
------------------	-------------------

### Discharge Characteristics

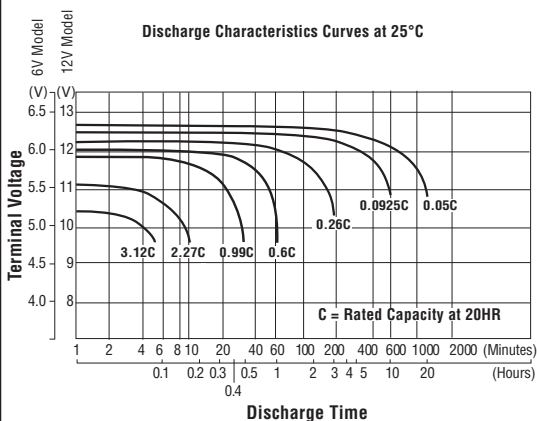

### Charging Characteristics

