

Series C / B 5800

Features

- DC input: 80 - 800 V
- AC input: 1 or 3-phase, 47 - 400 Hz
- DC output: 12 / ... / 400 V
- Continuous short circuit protection
- Overvoltage protection
- Thermal shutdown with auto restart
- Industrial grade components
- High efficiency through ZVS topology
- Compact and robust design



DC / DC Converters

▶ 12 KW							
Input VDC						Output VDC	
80–160 VDC	160–320 VDC	320–380 ¹⁾ VDC	320–640 VDC	450–800 VDC	Output Amps	Adj.	Range
▲ C 5854	▲ C 5874	▲ C 5884 Z	▲ C 5874 G	▲ C 5874 K	400	24	23– 26
▲ C 5855	▲ C 5875	▲ C 5885 Z	▲ C 5875 G	▲ C 5875 K	400	28	26– 30
▲ C 5859	▲ C 5879	● C 5889 Z	● C 5879 G	● C 5879 K	220	48	45– 55
▲ C 5856	▲ C 5876	● C 5886 Z	● C 5876 G	● C 5876 K	180	60	58– 68
▲ C 5857	▲ C 5877	● C 5887 Z	● C 5877 G	● C 5877 K	92	110	100– 130
▲ C 5857 J	▲ C 5877 J	● C 5887 ZJ	● C 5877 GJ	● C 5877 KJ	60	200	190– 200
▲ C 5858	▲ C 5878	● C 5888 Z	● C 5878 G	● C 5878 K	48	220	200– 250
▲ C 5858 J	▲ C 5878 J	● C 5888 ZJ	● C 5878 GJ	● C 5878 KJ	30	400	380– 400

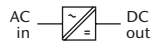

AC / DC Converters

▶ 8.5 KW		▶ 12 KW					Output VDC	
Input VAC, 1-Phase		Input VAC, 3-Phase			Output Amps	Adj.	Range	
115 ±20%	Output Amps	230 ^{+15%} _{-20%}	3x200 ^{+15%} _{-20%}	3x400 ^{+15%} _{-20%}				3x480 ^{+10%} _{-15%}
■ C 5863	400	—	—	—	—	15	14– 16	
■ C 5864	325	■ C 5884	■ C 5864 V	■ C 5884 V	■ C 5894 V	400	24	23– 26
■ C 5865	280	■ C 5885	■ C 5865 V	■ C 5885 V	■ C 5895 V	400	28	26– 30
■ C 5869	155	■ C 5889	■ C 5869 V	▼ C 5889 V	▼ C 5899 V	220	48	45– 55
■ C 5866	125	■ C 5886	■ C 5866 V	▼ C 5886 V	▼ C 5896 V	180	60	58– 68
■ C 5867	65	■ C 5887	■ C 5867 V	▼ C 5887 V	▼ C 5897 V	92	110	100– 130
■ C 5867 J	42	■ C 5887 J	■ C 5867 VJ	▼ C 5887 VJ	▼ C 5897 VJ	60	200	190– 200
■ C 5868	34	■ C 5888	■ C 5868 V	▼ C 5888 V	▼ C 5898 V	48	220	200– 250
■ C 5868 J	21	■ C 5888 J	■ C 5868 VJ	▼ C 5888 VJ	▼ C 5898 VJ	30	400	380– 400

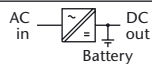

Battery Chargers

▶ 8.8 KW		▶ 12 KW					Output VDC	
Input VAC, 1-Phase		Input VAC, 3-Phase			Output Amps	Nom. Battery Voltage	Range	
115 ±20%	Output Amps	230 ^{+15%} _{-20%}	3x200 ^{+15%} _{-20%}	3x400 ^{+15%} _{-20%}				3x480 ^{+10%} _{-15%}
■ B 5861	400	—	—	—	—	12	12– 16	
■ B 5862	265	■ B 5882	■ B 5862 V	■ B 5882 V	■ B 5892 V	375	24	24– 32
■ B 5864	135	■ B 5884	■ B 5864 V	▼ B 5884 V	▼ B 5894 V	190	48	48– 64
■ B 5866	110	■ B 5886	■ B 5866 V	▼ B 5886 V	▼ B 5896 V	155	60	60– 80
■ B 5867	60	■ B 5887	■ B 5867 V	▼ B 5887 V	▼ B 5897 V	83	110	110– 145
■ B 5868	30	■ B 5888	■ B 5868 V	▼ B 5888 V	▼ B 5898 V	42	220	220– 290

Assistance in table use:

- 1 Select the column for input voltage range.
- 2 Select the row for the appropriate output voltage.
- 3 The intersection of both results in the module required.

For example:

- 1 input voltage = 3 x 400 VAC
- 2 output voltage = 220 VDC @ 48 A
- 3 results in a C 5888 V module.

¹⁾ input supply from PFC also suitable

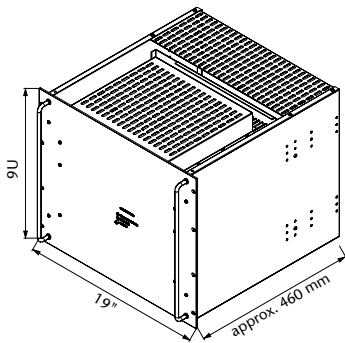

19" Plug-in module
▲ 50-65 kg ■ 65-75 kg

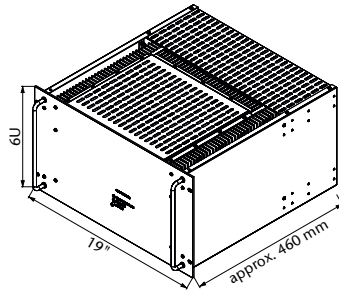

19" Plug-in module
● 35-50 kg ▼ 50-65 kg

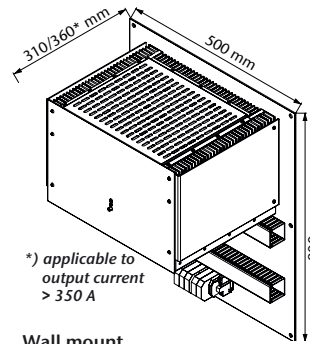

Wall mount
▼ ▲ 50-65 kg ■ 65-75 kg

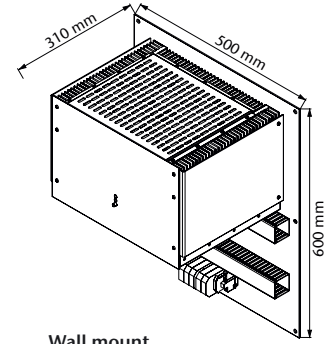

Wall mount
● 35-50 kg

Specifications

Input

Voltage range narrowing of input voltage range optimizes the efficiency (pls. specify), unit switches off at under- and overvoltage

No-load input power. 30 W typical

Switch-on time 0.5 s typical

Inrush current 3-phase AC input: limited by thermistor

Hold-up time AC input: 2.5 ms typical

Immunity

- ESD. acc. to DIN / EN 61000-4-2 level 3

- Fast transients acc. to DIN / EN 61000-4-4 level 3

- Surges acc. to DIN / EN 61000-4-5 level 3

Output

Line regulation ($\pm 10\%$) 0.1 %

Load regulation (10-90 %) 0.2 %

Load transient (10-90-10 %) 6 % typical

Response time to $\pm 1\%$ 10 ms typical

Turn-on rise time Soft-start, 300 ms typical

Ripple. $\leq 1\%$

Overload protection current limited to 105 - 110 % of I_{nom}

Overvoltage protection. OVP switches off module with automatic return to operation, after 5 seconds, the unit will remain latched off

Remote sense. standard for C series up to 150 V output, up to 10 % of U_{nom} for output < 60 VDC, up to 6 V for output > 60 VDC

General

Efficiency 80 - 95 %

Operating temperature. -20 to +75 °C

Load derating 2.5 % / °C from +55 °C

Storage temperature -40 to +85 °C

Humidity up to 95 % RH, non-condensing

Cooling with temperature controlled fans

Temperature coefficient 0.02 % / °C typical

Safety / Construction. acc. to DIN / EN 60950-1: 2003

Protection category. IP 20, others or NEMA upon request

EMI. acc. to EN 55022, class A, optionally class B

MTBF approx. 70,000 h @ 40°C acc. to MIL - HDBK - 217 E (notice 1)

Connector terminals / bolts / bars

Marking CE

Options

Input

- Inrush current limiting
- Reverse polarity protection for DC input

Output

- Parallel operation
- Redundant operation
- Inhibit (remote on / off)
- Reducing of current limiting at high ambient temperature

Signals

via open collector or relay contacts

- Power ok (input)
- DC ok (output)
- Sys-reset

Programming

- Output voltage or current via
 - potentiometer
 - analog signal
 - interface RS232 or IEEE488

Battery charger

- Temperature compensated charging voltage
- Automatic / manual selection of charging characteristic

Monitoring

- Input / output voltage or current via
 - analog signal
 - interface RS232 or IEEE488

Mechanics / environment:

- Wall mount
- Analog or digital V- and A-meter
- Increased mechanical strength
- Tropical protection
- Extended temperature range to -40°C