

DNR05-60 SERIES

AC/DC Single Output DIN Rail: 5 ~ 60 Watts



Features

- Rugged Design for Industrial Applications
- Up to 89% Efficiency
- Wide Adjustment Range
- DC OK 24 V Models
- DC Standby Versions
- Connector Options
- Full Power to +60 °C

Specification

Input

Input Voltage	• 90-264 VAC, 120-370 VDC: DNR05/10/18 85-264 VAC, 90-375 VDC: DNR30/60
Input Frequency	• 47-63 Hz
Inrush Current	• 5-18 W: 10/18 A at 115/230 VAC 30 W: 20/40 A at 115/230 VAC 60 W: 30/60 A at 115/230 VAC
Power Factor	• Meets EN61000-3-2 for class A equipment
Earth Leakage Current	• 0.8 mA max

Output

Output Voltage	• See tables
Output Voltage Trim	• See tables
Initial Set Accuracy	• $\pm 1\%$
Minimum Load	• No minimum load required
Start Up Delay	• <1000 ms
Start Up Rise Time	• <150 ms
Hold Up Time	• 5 W: 30/130 ms at 115/230 VAC 10 W: 25/100 ms at 115/230 VAC 18 W: 20/75 ms at 115/230 VAC 30 W: 20/30 ms at 115/230 VAC 60 W: 20/30 ms at 115/230 VAC
Line Regulation	• 5-18 W: $\pm 1.0\%$ max 30-60 W: $\pm 0.5\%$ max
Load Regulation	• 5-18 W: $\pm 2.0\%$ max 30-60 W: $\pm 0.5\%$ max
Transient Response	• 300 μ s for a 50% load change
Ripple & Noise	• 50 mV pk-pk, 20 MHz BW
Overvoltage Protection	• Output clamps at 120-145% Vnom
Overload Protection	• 105-145%
Short Circuit Protection	• 5-18 W: Trip and restart (Hiccup mode) 30-60 W: Constant power
Temperature Coefficient	• $\pm 0.03\%/^{\circ}\text{C}$

General

Efficiency	• See tables
Isolation	• 3000 VAC Input to Output 1500 VAC Input to Ground 500 VAC Output to Ground
Switching Frequency	• 100 KHz typical
Signals	• DC ON indicator LED Green: All models DC LOW indicator LED Red: 5-18 W models DC OK: 24 V 30-60 W models
MTBF	• 200 kHrs typical per MIL-HDBK-217F GF, +40 °C

Environmental

Operating Temperature	• -10 °C to +70 °C, derate linearly from +50 °C for 5 & 18 W models, +60 °C for all other models (See derating curves)
Cooling	• Convection-cooled
Operating Humidity	• 20-95% RH, non-condensing
Storage Temperature	• -25 °C to +85 °C
Shock	• 4 g, 22 ms, X, Y & Z axis
Vibration	• 1 g, 10 Hz to 500 kHz, along X, Y & Z axis

EMC & Safety

Emissions	• EN55022, level B conducted
Harmonic Currents	• EN61000-3-2, class A
Voltage Flicker	• EN61000-3-3 amendments 1 & 2
ESD Immunity	• EN61000-4-2, level 3 Perf Criteria A
Radiated Immunity	• EN61000-4-3, level 3 Perf Criteria A
EFT/Burst	• EN61000-4-4, level 3 Perf Criteria A
Surge	• EN61000-4-5, level 3 Perf Criteria A
Dips & Interruptions	• EN61000-4-11, 30% 10 ms, 60% 100 ms, 100% 5000 ms Perf Criteria A, B, B
Safety Approvals	• EN60950-1:2001, UL508, UL1310 - see note 3 & ratings table, CE Mark

Output Voltage	Output Voltage Trim	Current	Typical Efficiency	Model Number
5 V	4.50-5.75 V	1.000 A	69%	DNR05US05 ^(1,3)
12 V	10.80-13.80 V	0.420 A	72%	DNR05US12 ^(1,3)
15 V	13.50-17.25 V	0.340 A	72%	DNR05US15 ^(1,3)
24 V	21.60-28.80 V	0.210 A	72%	DNR05US24 ^(1,3)
5 V	4.50-5.75 V	2.000 A	73%	DNR10US05 ^(1,3)
12 V	10.80-13.80 V	0.840 A	75%	DNR10US12 ^(1,3)
15 V	13.50-17.25 V	0.670 A	76%	DNR10US15 ^(1,3)
24 V	21.60-28.80 V	0.420 A	76%	DNR10US24 ^(1,3)
5 V	4.50-5.75 V	3.000 A	75%	DNR18US05 ^(1,3)
12 V	10.80-13.80 V	1.500 A	77%	DNR18US12 ^(1,3)
15 V	13.50-17.25 V	1.200 A	77%	DNR18US15 ^(1,3)
24 V	21.60-28.80 V	0.750 A	77%	DNR18US24 ^(1,3)
5 V	5.00-5.50 V	6.000 A	79%	DNR30US05 ⁽¹⁾
12 V	12.00-14.00 V	2.500 A	84%	DNR30US12 ^(1,3)
24 V	24.00-28.00 V	1.250 A	86%	DNR30US24 ^(1,3)
48 V	48.00-55.00 V	0.625 A	86%	DNR30US48 ^(1,3)
5 V	5.00-5.50 V	10.000 A	79%	DNR60US05 ⁽¹⁾
12 V	12.00-14.00 V	5.000 A	86%	DNR60US12 ⁽¹⁾
24 V	24.00-28.00 V	2.500 A	89%	DNR60US24 ^(1,3)
48 V	48.00-55.00 V	1.250 A	89%	DNR60US48 ^(1,3)

Notes

1. Add suffix '-S' for spring clamp option.
2. 30-60 W models are suitable for battery-charging applications.
3. Approved to UL1310.

Derating Curves

DNR5-18 Models

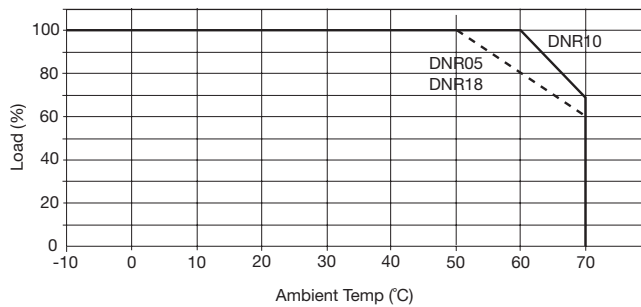

DNR30-60 Models

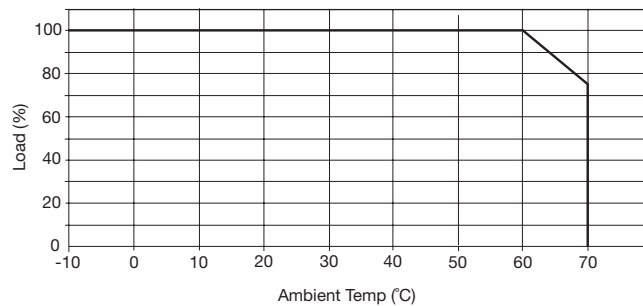

Mechanical Details
5/10/18 W Models

DNR05-60

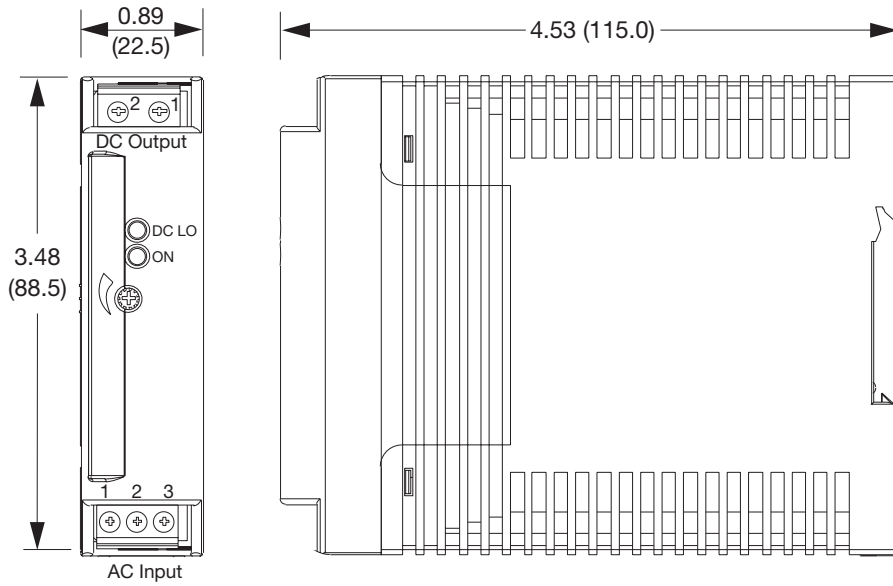

Notes

1. All dimensions in inches (mm).
2. Weight 0.33 lb (150 g) approx.

DNR05, 10, 18 Connections		
Conn	Pin	Designation
AC Input	1	Ground
	2	Neutral
	3	Line
DC Output	1	Positive
	2	Negative

30/60 W Models

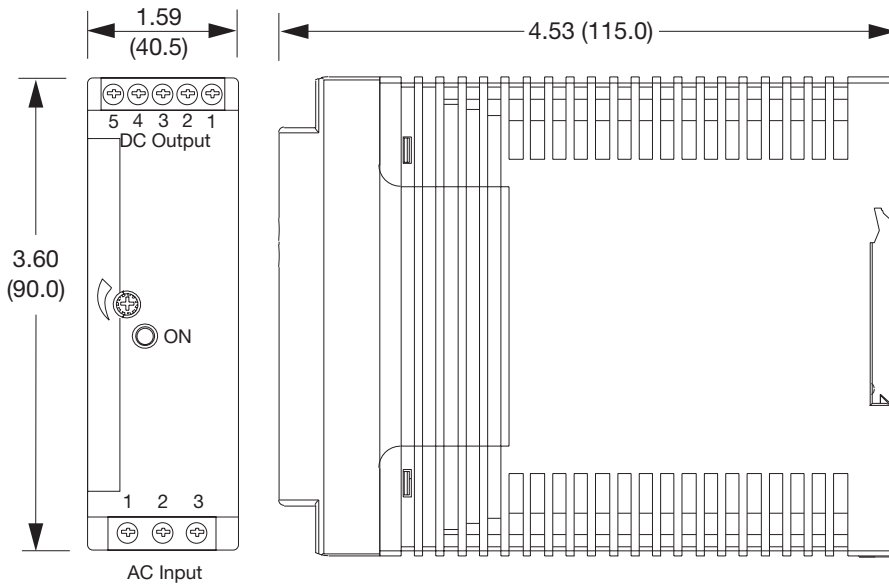

Notes

1. All dimensions in inches (mm).
2. Weight 0.6 lb (275 g) approx.

DNR30/60 Connections		
Conn	Pin	Designation
AC Input	1	Ground
	2	Neutral
	3	Line
DC Output	1	DC OK*
	2	Positive
	3	Positive
	4	Negative
	5	Negative

* 24 V models only.

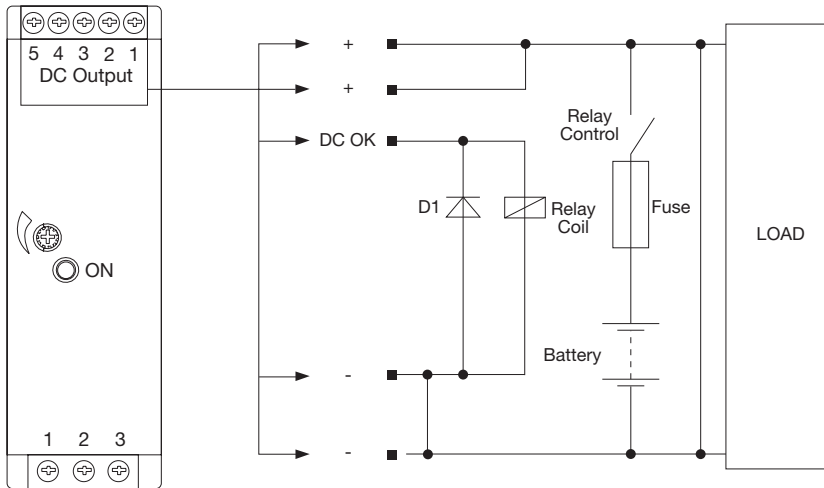

Maximum current drain from battery by PSU when inactive 22 mA.

DNR30/60 Connections		
Conn	Pin	Designation
AC Input	1	Ground
	2	Neutral
	3	Line
DC Output	1	DC OK*
	2	Positive
	3	Positive
	4	Negative
	5	Negative

DNR30/60 connection for DC standby system applications

Output Set Voltages For Standby Versions			
Model	Voltage	Current	Efficiency
DNR30US12*	13.6 V	2.20 A	84%
DNR30US24*	27.2 V	1.10 A	86%
DNR30US48*	54.5 V	0.55 A	86%
DNR60US12*	13.6 V	4.40 A	86%
DNR60US24*	27.2 V	2.20 A	89%
DNR60US48*	54.5 V	1.10 A	89%

Notes

*** at the end of the part number denotes DC standby system.

DC OK

30-60 W Models

Output good = 24 V

Output not good = 0 V

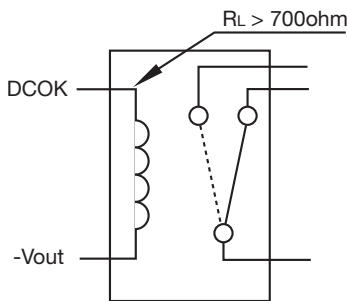

Example using external relay to create volt-free contact

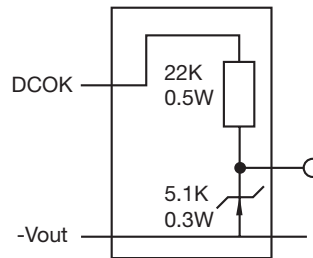

Example using external components to create TTL signal

Standard on 24 V models, 30-60 W only.