

## SR SERIES

### SR Series part numbering system and options

The SR part numbering system has been designed to depict the enormous flexibility of the product range and to facilitate smooth product selection and ordering.

#### 1. Unit types:

- A** Standard unit with single fixed output, secondary side current limit, may be set to nominal voltage or battery float - e.g. 48V units may be set to 55.2V or similar
- B** Automatic boost charger 3 stage with temperature compensation. For cyclic or standby charging application
- C** **No-Break™** unit including battery charge control, temperature compensation, alarm outputs, Low Voltage Disconnect. Optional regular battery condition testing.
- D** Type **A**, additionally with relay alarm outputs for power OK and battery (DC) low
- E** Type **B**, additionally with relay alarm outputs for power OK and battery (DC) low
- P** Type **D**, additionally including series diode at output for parallel / redundancy operation. Availability limited - for higher power units external diode required

#### 2. Output voltage designation

Output voltage is 2 digit code of nominal voltage. < 100V use actual: 12 = 12V, 24 = 24V, 48 = 48V (nominal)  
For ≥ 100V use as follows: 91 = 96V, 92 = 108V, 93 = 120V (nominal)

#### 3. Options available

- T** Temperature compensation of output voltage for battery charging. Standard for all unit types **B** and **C**, option for type **A** and **D**
- F** Internal cooling fan fitted
- S / X** Output connector type: **X** = Phoenix plug in 'combicon' terminal block, **S** = stud connectors at output (not recommended for output voltage > 60V DC for safety reasons)
- L / U** Denotes input voltage and switch / LED indicators (at opposite end of unit to terminals to enable the user to view and/or control the unit). **L** and **U** are preferred version units. **L** = 230VAC + switch, **U** = 110VAC + switch, **H** = 110VDC + switch, blank = 230VAC no switch, **G** = 110VAC no switch, **J** = 110VDC no switch

Please refer to following page for availability of specific models and list of preferred models

### SR No-Break™ III SERIES FULL ITEM CODING EXAMPLE

# SR250C 12 T F S L

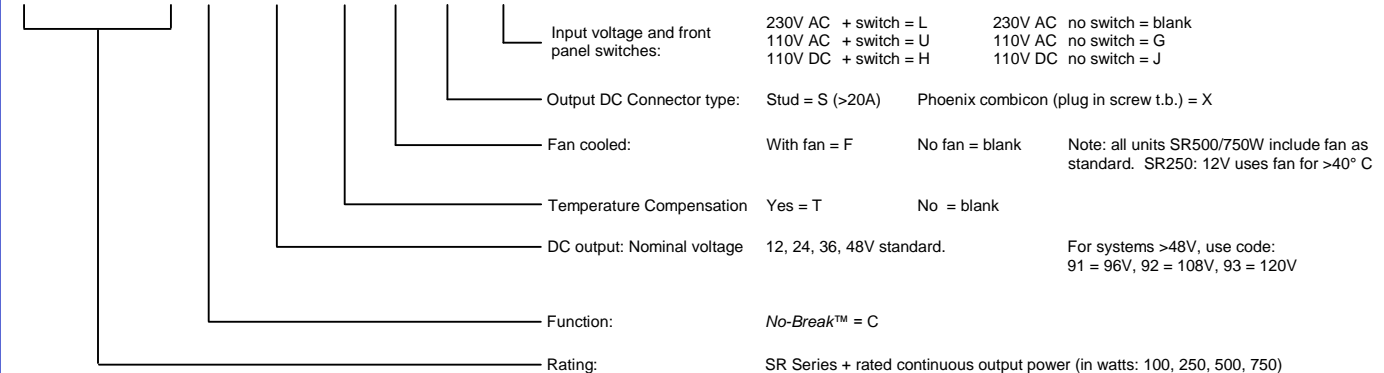

Note: Battery condition testing of customer specified interval and duration can be incorporated to the unique requirements of the application. Please contact us for details.

VALID FEATURES AND OPTIONS													
Option	Wattage / Voltage	SR100			SR250			SR500			SR750		
		12V	24V	48V	12V	24V	48V	12V	24V	48V	12V	24V	48V
<b>Main Functionality</b>													
A - Standard single rail (PSU or charger)		Y	Y	Y	Y	Y	Y	Y	Y	Y	Y	Y	Y
B - <i>SmartCharger</i> (Boost charger)		Y	Y	Y	Y	Y	Y	Y	Y	Y	Y	Y	Y
C - <i>No-Break™</i> system		Y	Y	Y	Y	Y	Y	Y	Y	Y	Y	Y	Y
D - Standard single rail with alarms		Y	Y	Y	Y	Y	Y	Y	Y	Y	Y	Y	Y
E - <i>SmartCharger</i> with alarms		N	N	N	Y	Y	Y	Y	Y	Y	Y	Y	Y
P - Parallel redundancy single rail		N	Y	Y	#1	Y	Y				Note #1		
<b>Temperature compensation option</b>													
With tempco		Y	Y	Y	Y	Y	Y	Y	Y	Y	Y	Y	Y
Without tempco		Y	Y	Y	Y	Y	Y	Y	Y	Y	Y	Y	Y
<b>Output connection option</b>													
Phoenix 20A socket / plug combination		Y - Note #4			N	Y	Y	N	Y	Y	N	N	Y
Stud connection (SR250: M6, SR500/750: M8)		N	N	N	Y	Y	Y	Y	Y	Y	Y	Y	Y
<b>Fan option</b>													
With fan		N	N	N	Y	Y	Y	Y - Note #3					
Without fan		Y	Y	Y	#2	Y	Y	N	N	N	N	N	N
<b>Input voltage, LEDs &amp; switches option</b>													
L - 230V AC with LEDs and switches		N	N	N	Y	Y	Y	Y	Y	Y	Y	Y	Y
U - 110V AC with LEDs and switches		N	N	N	Y	Y	Y	Y	Y	Y	Y	Y	Y
H - 110V DC with LEDs and switches		N	N	N	Y	Y	Y	Y - Note #5					
Blank - 230V AC no LEDs and switches		Y	Y	Y	Y	Y	Y	Y	Y	Y	Y	Y	Y
G - 110V AC no LEDs and switches		Y	Y	Y	Y	Y	Y	Y	Y	Y	Y	Y	Y
J - 110V DC no LEDs and switches		Y	Y	Y	Y	Y	Y	Y - Note #5					

**Note #1:**

The output coupling diode needs to be mounted outside the PSU case.  
The recommended configuration would be to use a 'D' type PSU (single rail PSU with alarm) in a 2U rack frame with coupling diode mounted next to PSU in the 2U rack frame.

**Note #2:**

No fan version only recommended for operation in ambient temperatures to 35° C

**Note #3:**

SR500 and SR750 series units always include fan as standard

**Note #4:**

SR100 has 12A rated terminal block and no option for stud connection

**Note #5:**

DC input types of SR500 and SR750 do not provide secondary current limit into a short circuit

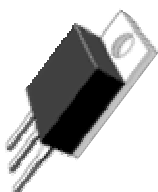

**LIST OF PREFERRED SR SERIES POWER SUPPLIES**

SR100	SR250	SR500	SR750
SR100A12X	SR250A12FSL	SR500A12FSL	SR750A12FSL
SR100A24X	SR250A24XL	SR500A24FSL	SR750A24FSL
SR100A48X	SR250A48XL	SR500A48FSL	SR750A48FSL
SR100B12TX	SR250B12TFSL	SR500B12TFSL	SR750B12TFSL
SR100B24TX	SR250B24TXL	SR500B24TFSL	SR750B24TFSL
SR100C12TX	SR250C12TFSL	SR500C12TFSL	SR750C12TFSL
SR100C24TX	SR250C24TXL	SR500C24TFSL	SR750C24TFSL
SR100C48TX	SR250C48TXL	SR500C48TFSL	SR750C48TFSL
	SR250D12FSL	SR500D12FSL	SR750D12FSL
	SR250D24FXL	SR500D24FSL	SR750D24FSL
	SR250D48FXL	SR500D48FSL	SR750D48FSL
	SR250E12TFSL	SR500E12TFSL	SR750E12TFSL
	SR250E24TXL	SR500E24TFSL	SR750E24TFSL

**PARALLEL REDUNDANCY / SERIAL CONNECTION INFORMATION**

**Application Solution #1**

2 x SR No-Break™ units for increased power output. No diodes shown (see #2) but may be inserted for partial redundancy.

It is valid to install two No-Break™ units parallel connected, one battery string as follows, noting the specific requirement for equal wiring:

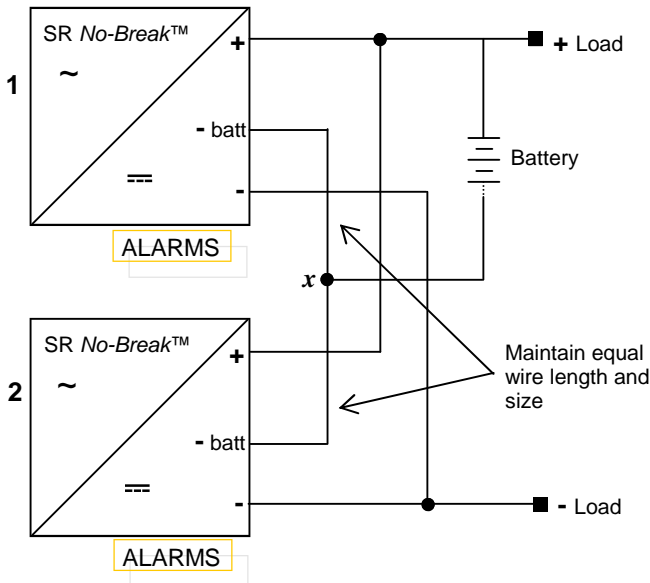

Notes: The wires which common the battery negative lead ('-batt' terminal to common point 'x') **must be** of the same type / gauge and equal in length.

**Application Solution #2**

2 x SR No-Break™ units and 2 x battery strings for increased redundancy

For the extreme in redundancy, the user can install two No-Break™ units parallel connected, two battery strings, noting the requirements for external diodes.

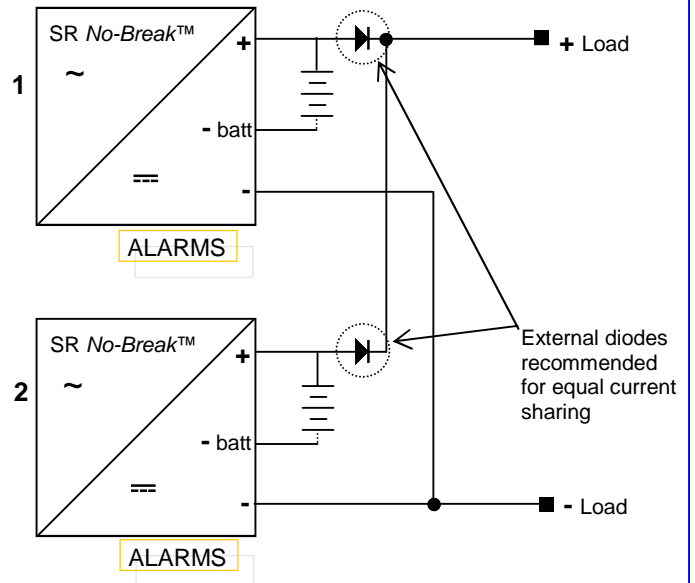

This solution provides an increased level of redundancy and is a rarely used but a proven method of providing redundancy of the battery in addition to the power supply. The additional diodes also aid current sharing and isolate the units from one another in the event of a short circuit appearing at the other output.

**Application Solution #3**

Two SR xxx D (Standard PSU with alarms) units may be connected in parallel for increased power or redundancy 'n+1'

Note that SR500 & SR750 models require diodes to be mounted external to PSU due to extra heat dissipation.

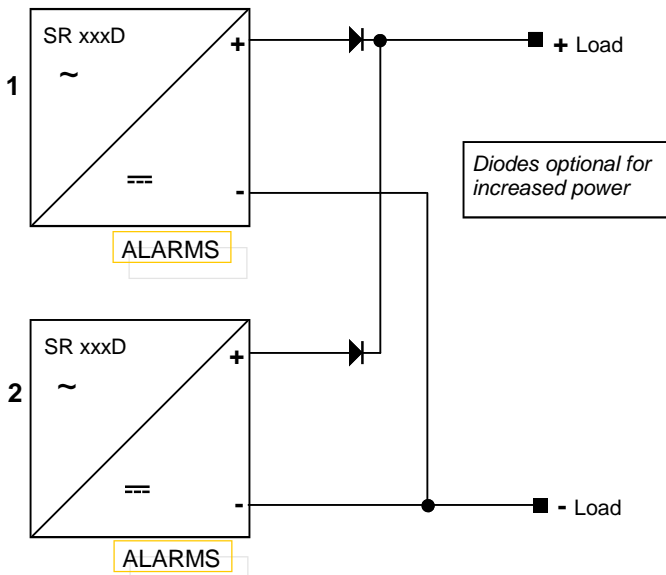

Multiple units may be used to provide increased power and maintain redundancy. Normal practice is to install one additional unit than is necessary to power the load, thus the system is not compromised if one unit fails. For SR 250xxx units, diodes are installed internally.

**Application Solution #4**

Two SR xxx D (Standard PSU with alarms) units series connected for double output voltage

An example of this solution would be the requirement for 100V DC. The preferred solution is to use a specifically designed unit with the desired output, but if urgent or impractical, units can be connected as shown.

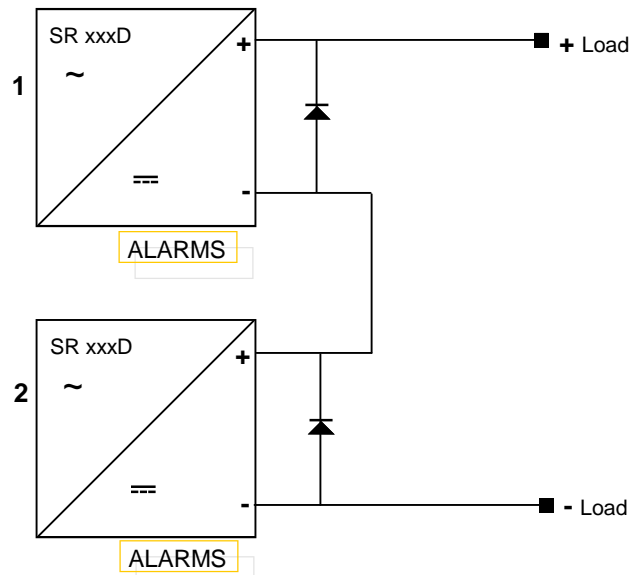

Diodes shown are essential.