

## User Manual

### SR100A

#### AC/DC POWER SUPPLY & FLOAT CHARGER FOR LEAD ACID BATTERIES

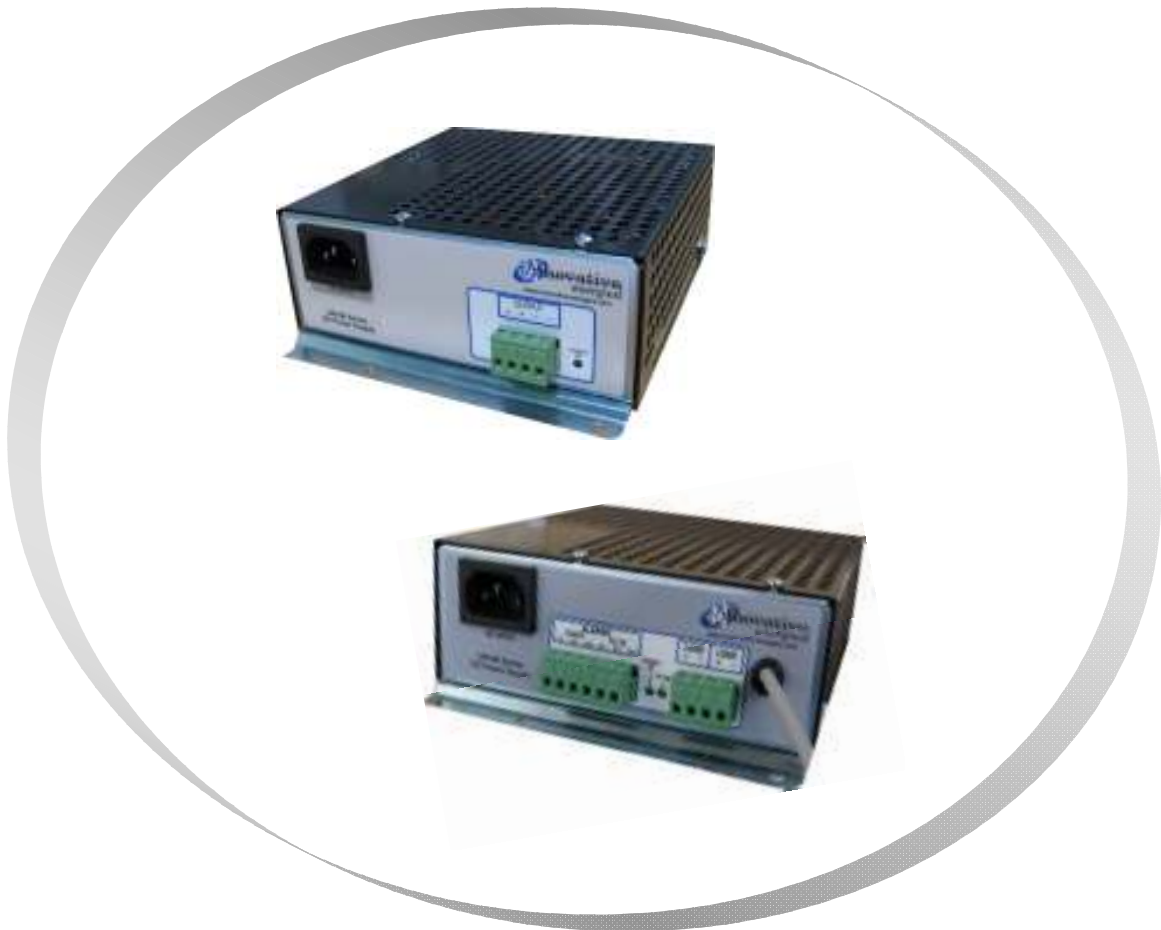

**Model Codes:**

- SR100A .... Standard version
- SR100D .... Standard with 2 relay alarm outputs
- SR100L .... Standard with 3 relay alarm outputs
- SR100P.... Standard with 2 alarms and internal output diode

## 1. INTRODUCTION

The **SR100A** range is designed for use as a very accurate AC to DC power supply, or float charger for lead acid batteries. Note that for float charging the output voltage must be set to approximately 15% above the nominal battery voltage. This is done as the default voltage for the 12V model but must be specified at time of order for all higher voltage models.

## 2. CONNECTIONS

If used as a float charger always connect the positive output of the power supply to the positive terminal of the battery. The charger may be permanently connected to float charge lead acid batteries but it is essential to periodically check the electrolyte level of flooded cells as there is always some evaporation. To minimize the volt drop at the output connections use all the terminals provided ie. connect output wires in parallel.

### CONNECTION LAYOUTS

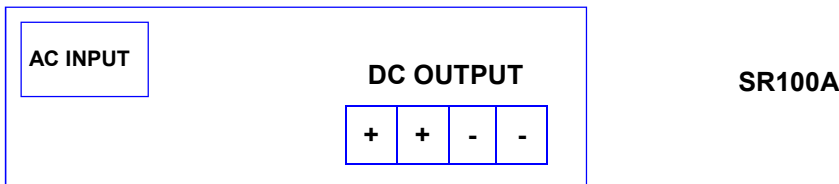

### ALARM VERSIONS

Relay contacts shown in **de-energised** state (ie when there is a fault condition).

Alarm relays are **energised** when power supply is operating normally, eg. "Power" alarm relay is energised when ac input is present.

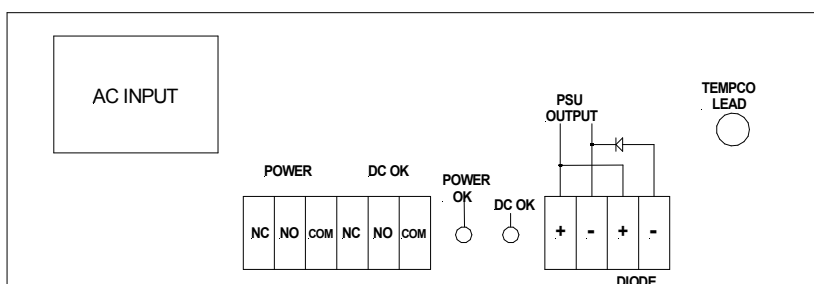

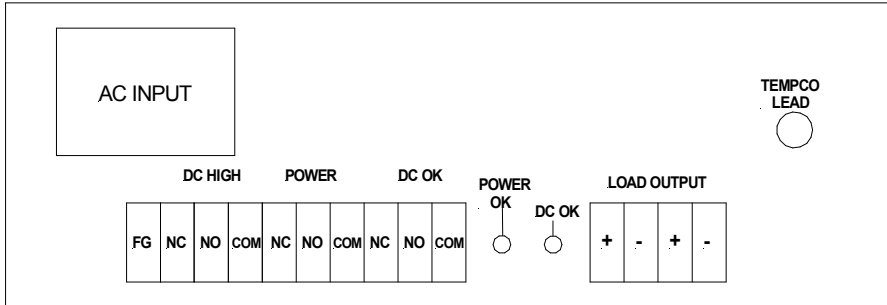

**SR100L (tempco optional)**

### 3.0. LED INDICATION CODES

#### 3.1 -D version

**Power:** On = ac input present  
Off = no input or short circuit on output

**DC OK:** Steady on = DC output OK  
Slow flash = DC output low or battery low (eg. 11, 22, 33, 44V)

#### 3.2 -L Alarm version

**Power:** On = ac input present  
Off = no input or short circuit on output

**DC OK :** Steady on = DC output OK  
Slow flash = DC output low or battery low (eg. 11, 22, 33, 44V)  
Fast flash = DC high (1.2xVnom for PSU, 2.5V/cell for charger, unless otherwise specified)

### 4.0 FG - Frame Ground

Where provided, this terminal provides a connection to the metal case for an earthing point.



*Ideal as a Standby Float Charger  
for lead acid batteries*

◆ 24 Month Warranty

**SPECIFICATIONS** All specifications are typical at nominal input, full load and at 20°C unless otherwise stated.

### ELECTRICAL

<b>Input</b>	180V - 264VAC 45-65Hz or 200 - 375V DC (standard)  88V - 132VAC 45-65Hz or 110-180VDC (on request)
<b>Fusing / Protection</b>	Internal AC input fuse
<b>Isolation</b>	1KV DC input - output / earth
<b>Efficiency</b>	≥ 85%
<b>Inrush current</b>	<30A, 1.8ms
<b>Output Power</b>	100W Continuous (0 - 50°C)
<b>Output Voltages (nominal)</b>	13.8V, 24V, 36V, 48V Other voltages by request.
<b>Voltage adj. range</b>	85 - 115% of Vout
<b>Temp. Compensation (option)</b>	Temperature sensor on 1.7m lead with adhesive pad: -4mV / °C / cell ±10%
<b>Over current Protection</b>	Constant current limit under overload and short circuit conditions
<b>Line Regulation</b>	<0.04% over input range
<b>Load Regulation</b>	<0.5% open circuit to 100% load
<b>Noise</b>	<0.3%
<b>Transient response</b>	200mV over/ undershoot, load step 20-100%, 400us settling time
<b>Hold-up time</b>	15 - 20 ms (nom. - max. Vin) without battery

### PHYSICAL

<b>AC Input connector</b>	IEC320 inlet socket (similar to PCs etc.)
<b>DC Connections</b>	Plug-in style socket & mating screw terminal block: (max. wire 2.5mm <sup>2</sup> / way)
<b>Enclosure</b>	Zinc plated steel / powder coated lid
<b>Indicators</b>	Green LED for DC Power OK
<b>Weight</b>	0.94 Kg
<b>Dimensions</b>	146.5 W x 62 H x 177 D mm

### ENVIRONMENTAL

<b>Operating temperature</b>	0 - 50 °C ambient at full load De-rate linearly >50 °C to 0 load @ 70 °C
<b>Storage temperature</b>	-10 to 85 °C ambient
<b>Humidity</b>	0 - 95% relative humidity non-condensing
<b>Cooling</b>	Natural convection

### STANDARDS

<b>EMI</b>	to CISPR 22 / EN55022 class A
<b>Safety</b>	to IEC950 / EN60950 / AS/NZS3260

### ACCESSORIES SUPPLIED

Mounting Feet together with screws  
AC power cord Standard 1.5m lead with IEC320 socket / local plug  
DC connectors with mating screw-terminal plug

# 100 Watt AC/DC Stand Alone Power Supply/Float Charger

# SR100A

incl. SR100D, SR100P, SR100L

## STANDARD MODEL TABLE

MODELS	Power Supply		Battery Charger*		Adjustable range (V)
	Output Volts (factory default)	Output Current (A) (continuous)	Output Volts* (Charging)	Output Current (A) (Charging)	
SR100A12	13.8	7.3	13.8	7.3	11-14
SR100A24	24	4.2	27.6	3.6	22-28
SR100A30	30	3.3	34.5	2.9	27-33
SR100A36	36	2.8	41.4	2.6	34-43
SR100A48	48	2.1	55.2	1.8	45-57

\*Please specify on ordering if unit is to be used for battery charging duty (except for 12V version which is set for 13.8V as standard)

## OPTIONAL COMMUNICATION PORT

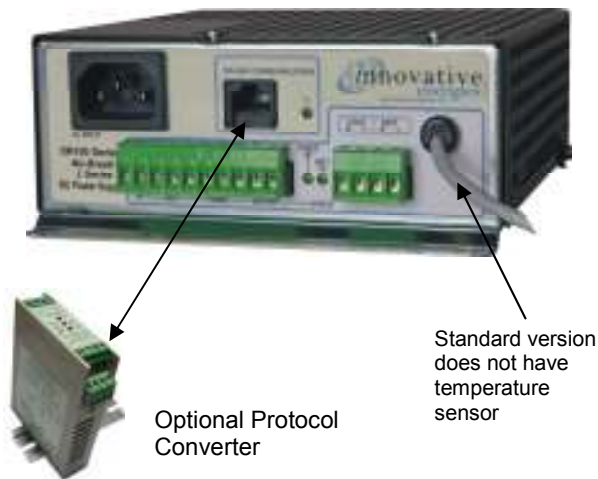

Optional Protocol Converter

Standard version does not have temperature sensor

### Available on SR100L... models:

- Three comms. options available: RS485, RS232, Ethernet
- With three relay alarm outputs
- Optional MODBUS protocol converter

## CABINET OPTIONS

- 19" Rack mount**      2U sub rack option: add **SR-RM2U**
- Wall Mount Cabinet**      May be fitted into a cabinet which includes two MCBs and I/O terminals  
Cabinet code: **SEC-SR**

## ELECTRICAL OPTIONS

- Temperature Compensation**      For accurate battery charging, temperature compensation adjusts voltages in accordance with external temperature probe  
Order Code: **+TEMPCO**
- Alarms : SR100D**
- **Mains fail**
  - **DC low** (Battery low or PSU low)
    - Charger: set at 1.83V/cell (80% Vout)
    - PSU: set at 83% V out
- SR100L**
- **As SR100D plus extra DC alarm and optional comms port**
- Alarm Relay Contacts**      C - NO - NC changeover, rated 30VDC,2A /110VDC,0.3A/125VAC,0.5A
- Parallel Redundancy**      Use output diode for N+1 redundancy  
**24V & above:** SR100P with alarms and internal diode  
**12V:** use SR100D12.. and **+P15** external diode

## MODEL CODING

# SR100A12TXG-485

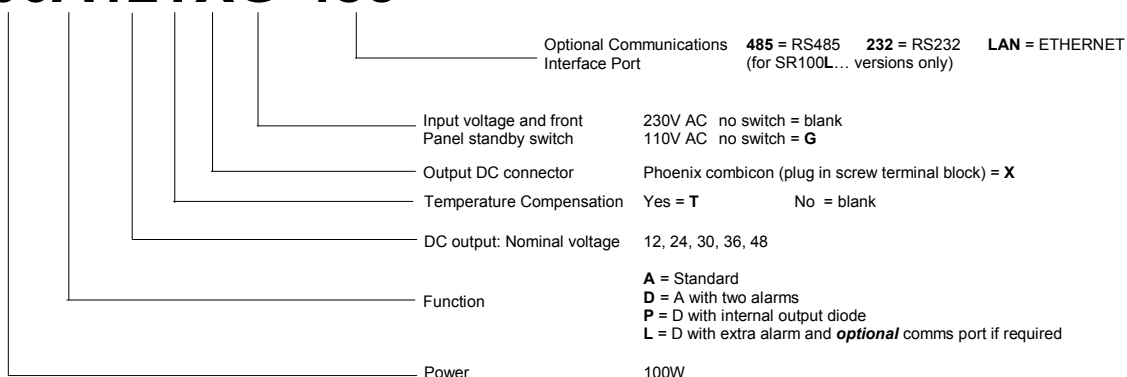

## CONNECTION FOR PARALLEL REDUNDANCY

Two or more SRxxx A series power supplies may be connected in parallel for increased power (with or without diodes). It is essential that the wiring from each unit to the load is kept identical for equal power sharing particularly when diodes are not used.

Two or more SRxxx D series power supplies (standard PSU with alarms), may be connected in parallel for N+1 redundancy using output diodes shown.

Diodes can be fitted inside some power supplies (see models listed below). The SRxxx P series identifies when an internal diode is fitted in the power supply.

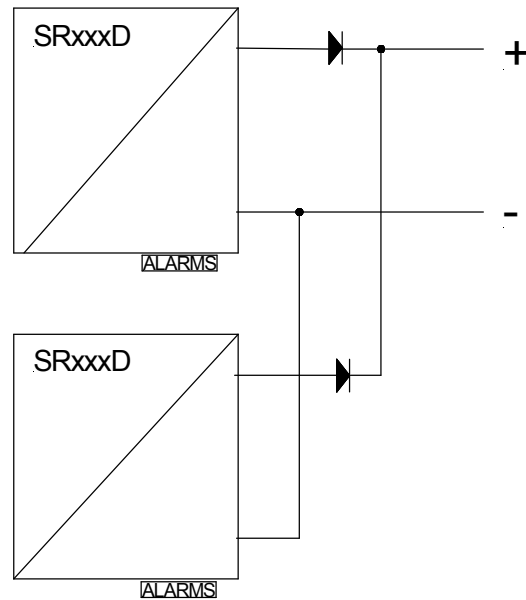
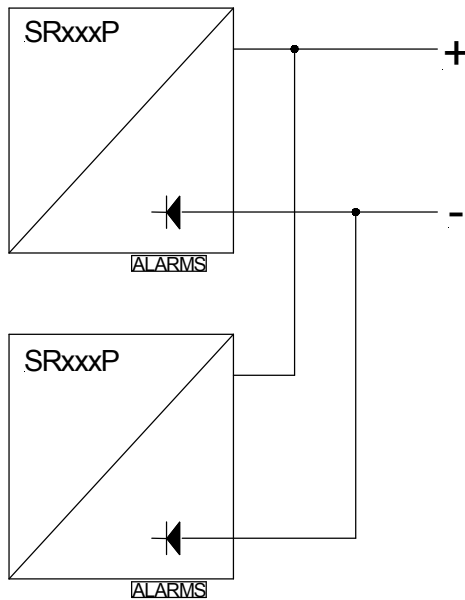

**INTERNAL** diodes can be fitted to the following models only (diode is fitted in negative line):

- 100W:** SR100P24, SR100P36, SR100P48
- 250W:** SR250P24, SR250P30, SR250P36, SR250P48, SR250P60

All other models have diodes external to the power supply, eg fitted into a 2U rack as shown in the photo to the right.



2U rack with 2 x SR250D12 power supplies and decoupling diodes on heatsink plus V/I meter

## Safety

The user is responsible for ensuring that input and output wiring segregation complies with local standards and that in the use of the equipment, access is confined to operators and service personnel. A low resistance earth connection is essential to ensure safety and additionally, satisfactory EMI suppression (see below).

**HAZARDOUS VOLTAGES EXIST WITHIN A POWER SUPPLY ENCLOSURE AND ANY REPAIRS MUST BE CARRIED OUT BY A QUALIFIED SERVICEPERSON.**

## Electrical Strength Tests

Components within the power supply responsible for providing the safety barrier between input and output are constructed to provide electrical isolation as required by the relevant standard. However EMI filtering components could be damaged as result of excessively long high voltage tests between input, output and ground. Please contact our technicians for advice regarding electric strength tests.

## Earth Leakage

The EMI suppression circuits causes earth leakage currents which may be to the maximum allowable of 3.5mA.

## Ventilation

High operating temperature is a major cause of power supply failures, for example it has been well documented that a 10°C rise in the operating temperature of a component will halve its expected life. Therefore always ensure that there is adequate ventilation for the equipment. Batteries and cooling fans also suffer shortened lifetimes if subjected to high ambient temperatures - both should be included in a routine maintenance schedule to check for signs of reduced efficiency.

## Water / Dust

Every effort must be made in the installation to minimise the risk of ingress of water or dust. Water will almost always cause instant failure. The effects of dust are slower in causing failure of electronic equipment but all electrical equipment should be cleaned free of any dust accumulation at regular intervals.

## Electromagnetic Interference (EMI)

Switching power supplies and converters inherently generate electrical noise. All wiring should be as short as practicable and segregated from all equipment wiring which is sensitive to EMI. Residual noise can be reduced by looping DC wiring through ferrite cable sleeves. These are most effective as close to the power supply as possible and as many turns of the wire taken through the core (+ and - in the same direction) as the core will accommodate.

## Fuse ratings

Check that the wiring and fuses or MCBs match the rating of the PSU or converter. Note that the Innovative Energies *No-Break™* DC chargers are able to deliver up to 2.5 times the rated current when mains power is on.

## Connection polarity

It is critical to check the polarity carefully when connecting DC devices. Some Innovative Energies models have reverse polarity protection (RPP), for example, the *Smartchargers* have electronic (non-destructive) RPP, the *No-Break™* DC range has an internal fuse which needs to be replaced if the battery is connected in reverse. Usually, however, a reverse polarity connection results in instant destruction of the device, especially if there is a battery involved.

## Glossary of terms used in our user manuals

**PSU** = power supply unit

**BCT** = battery condition test

**ECB** = electronic circuit breaker

**ELVD** = electronic low voltage disconnect

**RPP** = reverse polarity protection

**EMI** = electromagnetic interference

**SNMP** = Simple Network Management Protocol

**LAN** = local area network

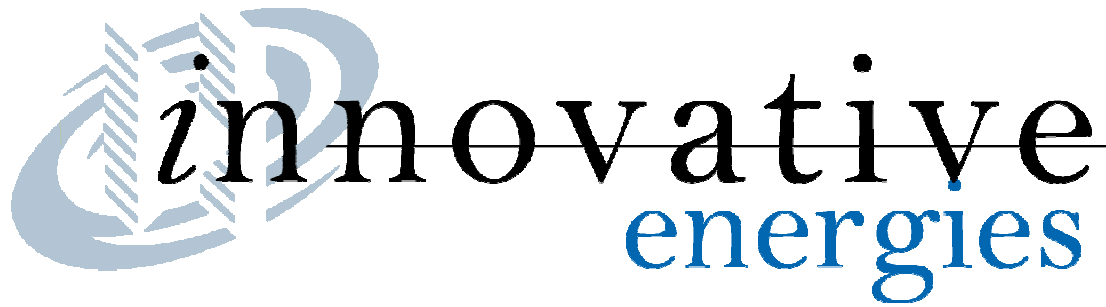

*Global Solutions Personal Focus*

**TERMS OF WARRANTY**

Innovative Energies Ltd warrants its power supplies for 24 months (two years) from date of shipment against material and workmanship defects.

Innovative Energies' liability under this warranty is limited to the replacement or repair of the defective product as long as the product has not been damaged through misapplication, negligence, or unauthorized modification or repair.

Thank you for purchasing from Innovative Energies.

We trust your power supply will exceed your expectations and perform for years to follow.

Sincerely,  
The Innovative Energies team.

**Innovative Energies Limited**

Phone: +64 9 835 0700  
Freephone: 0800 654 668 (New Zealand)  
1800 148 494 (Australia)  
Fax: +64 9 837 3446  
Email: [info@innovative.co.nz](mailto:info@innovative.co.nz)  
Online: [www.innovative.co.nz](http://www.innovative.co.nz)  
In Person: 1 Heremai Street, Henderson, Auckland, New Zealand  
By Post: PO Box 19-501, Auckland 1746, New Zealand

